



# medTAB<sup>®</sup>

## **USER MANUAL**

Document Number: PD196-448R5

For model numbers  
medTAB16E/ medTAB22E

**This manual is intended for qualified installers and hospital IT staff.  
Please read the safety and operating instructions and retain this document for future reference.**

## medTAB User Documents

This medTAB comes with the following manuals. Please scan QR codes 1 & 2 below to access these resources. QR code 3 gives you access to the entire PDi document library.

- **User Manual (This document):** Safety information, medTAB installation, and setup guidelines
- **GENiO Manual:** Instructions on setting up GENiO, PDi's cloud-based patient engagement platform
- **IPTV Guide:** IPTV setup guidelines



1. medTAB16E



2. medTAB22E



3. PDi Document Library

### Pre-install checklist

Included in your package:

- medTAB
- Spacers and screws (may or may not be included)

**The following important accessories are not included in your package and must be ordered separately:**

- PDi-approved Power Supply (for coax-powered models)
- Or UL-listed PoE Power Sourcing Equipment (60W per port)
- Solid Copper Coaxial Cable
- Or CAT5e (or better) Ethernet Cable
- PDi Suspension Arm
- Or 75mm x 75mm VESA Mounting Bracket
- Programming Remote PD108-520



**Please have all necessary items on hand before beginning installation.**

## Table of Contents

IMPORTANT SAFETY INSTRUCTIONS .....	5
IMPORTANT SAFETY INSTRUCTIONS .....	6
IMPORTANT SAFETY INSTRUCTIONS (FRENCH).....	7
PART I: INSTALLATION .....	8
POWER AND CABLING REQUIREMENTS .....	8
Coax Cable Specifications.....	8
CATEGORY CABLE SPECIFICATIONS.....	8
INSTALLING AND REMOVING THE MEDTAB.....	8
Installing a top mounted medTAB on Suspension Arm .....	8
Removing a Top-Mounted medTAB from Suspension Arm.....	9
Installing a Rear Mounted medTAB.....	9
PART II: SETTING UP THE MEDTAB .....	11
REMOTE CONTROLS & KEYBOARDS .....	11
Programming Remote Control.....	11
Pillow Speakers (Optional).....	11
SETUP WIZARD.....	12
Wi-Fi Selection.....	12
POPULAR CONFIGURATION SETTINGS .....	13
Device Management.....	13
IPTV SETTINGS .....	13
OPTIONAL SETTINGS .....	13
DISPLAY MODE .....	14
Closed Captions.....	14
Multi-audio / SAP Audio.....	14
CHANNEL SETUP.....	14
Service Level.....	14
Configure Channels.....	15
Channel Sources (Auto Program).....	15
Mode Option Settings.....	16
Search Option Settings .....	16
Deleting Channels from Channel Map .....	16
Parental Controls .....	16
Channel Sequence .....	16
Power On Channel.....	16
Channel Lock.....	16
CH Override/Auto Update.....	16
Auto Channel Alias .....	17
Clear Service Level .....	17

Copy Service Level .....	17
medTAB TV Settings .....	17
PICTURE SETTINGS.....	17
Picture Mode .....	17
Backlight .....	17
Advanced.....	17
SOUND SETTINGS .....	18
Sound Mode.....	18
Treblebass.....	18
Balance .....	18
Auto Volume .....	18
Advanced Sound Effects .....	18
LANGUAGE.....	18
A/V SOURCES .....	18
Source Enable.....	19
Power on Source.....	19
HDMI CEC AND HDMI ARC AUDIO LATENCY .....	19
DATE AND TIME .....	19
FEATURES.....	19
Channel to Other Sources .....	19
Sleep Timer .....	19
Menu Timer.....	19
CONTROL BAR.....	20
SYSTEM.....	20
Diagnostics .....	20
Security.....	20
Settings.....	20
USB CLONING .....	21
Firmware Update – USB and Over-the-Air (OTA).....	21
OTA Update .....	21
USB Firmware Update .....	21
Change PIN/Passwords for Settings Menus .....	21
TROUBLESHOOTING TIPS .....	22
LIMITED WARRANTY.....	22

## IMPORTANT SAFETY INSTRUCTIONS

	This symbol indicates that dangerous voltage constituting a risk of electric shock is present within this unit.
	This symbol indicates that there are important operating and maintenance instructions in the literature accompanying this unit.

	<b>CAUTION</b>	
RISK OF ELECTRIC SHOCK, DO NOT OPEN!		
CAUTION: TO REDUCE THE RISK OF ELECTRIC SHOCK, DO NOT REMOVE COVER. NO USER SERVICEABLE PARTS INSIDE. REFER SERVICING TO QUALIFIED SERVICE PERSONNEL		



### Overhead Falling Hazard

medTAB can pose a striking hazard when mounted at an elevated position. Use only PDi mounting brackets, support arms, and appropriate hardware to assure device will not fall from the mounted position. Failure to do so may cause injury or death.



### Rain and Moisture

**WARNING:** To avoid the hazards of fire or electrical shock, DO NOT expose this product to rain or moisture.



### Oxygen Environment

**WARNING:** Do not use in any oxygen tent or oxygen chamber. Such use may cause a fire hazard.



### Wet Locations

Do not use this product near water. Product shall not be exposed to dripping or splashing and no objects filled with liquids, such as vases, shall be placed on the product.

### Note to Cable TV Installer

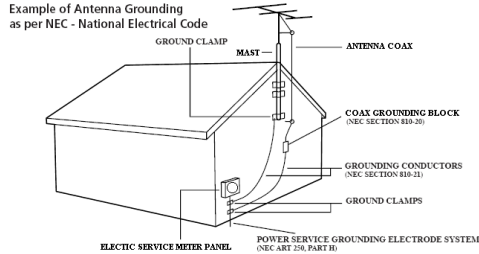

This reminder is provided to call the cable TV system installer's attention to Article 820-40 of the National Electrical Code.

The code provides guidelines for proper grounding and specifies that the cable ground shall be connected to the grounding system of the building, as close to the point of the cable entry as practical. Canadian installations shall be properly grounded in accordance with the Canadian Electrical Code, Part 1.

### FCC

This equipment has been tested and found to comply with the limits for a Class A digital device, pursuant to part 15 of the FCC Rules. These limits are designed to provide reasonable protection against harmful interference when the equipment is operated in residential or commercial installation. If this

equipment does cause harmful interference to radio or product reception, which can be determined by turning the equipment off and on, the user is encouraged to try to correct the interference by one or more of the following measures:

- Reorient or relocate the receiving antenna.
- Increase the separation between the equipment and receiver.
- Connect the equipment into an outlet on a circuit different from that to which the receiver is connected.
- Consult the dealer or an experienced radio/TV technician for help.

### Cleaning and Disinfection

Clean the exterior of this product by removing dust with a lint-free cloth. Spot test a new disinfectant by test cleaning a non-obvious small spot on the TV's back cabinet, keypad, and LCD panel. PDi recommends using a premoistened disinfectant cloth, like PD600-001 Super Sani-Cloth or similar, or spraying cleaner onto a dry cloth and then wiping the unit. Specific recommendations can be found at [www.pdiarm.com](http://www.pdiarm.com). **CAUTION:** To avoid damage to the surface of the product, do not use abrasive or chemical cleaning agents.

### Copyright, Trademarks

© 2026 PDi Communication Systems, Inc. All rights reserved. PDi, medTV® and medTAB® are registered trademarks of PDi Communication Systems, Inc. Manufactured under license from Dolby Laboratories. Dolby, Dolby Audio, and the double-D symbol are trademarks of Dolby Laboratories Licensing Corporation. The terms HDMI, HDMI High-Definition Multimedia Interface, and the HDMI Logo are trademarks or registered trademarks of HDMI Licensing Administrator, Inc. Product logos, brands and other trademarks displayed within PDi's products are the property of their respective trademark holders, who are not affiliated with, endorsing, or sponsoring PDi Communication Systems, Inc. or our products.

### Underwriters Laboratories



This model Hospital Grade medTAB is a specialized device and should be installed to National Electrical Code specifications. This device is safety tested and listed by the Underwriters Laboratories as a product suitable for use in healthcare facilities in both the United States and Canada.

## IMPORTANT SAFETY INSTRUCTIONS

**THIS INSTALLATION SHOULD BE MADE BY A QUALIFIED SERVICE PERSON AND SHOULD CONFORM TO ALL LOCAL CODES. READ AND FOLLOW THE SAFETY INSTRUCTIONS BEFORE ATTEMPTING THIS INSTALLATION.**

1. Read these Instructions – All the safety and operating instructions should be read before the product is operated.
2. Keep these Instructions – The safety and operating instructions should be retained for future reference.
3. Heed all warnings – All warnings on the product and in the operating instructions should be adhered to.
4. Follow all instructions – All warnings on the product and in the operating instructions should be followed.
5. Do not use this apparatus near water – for example, near a bathtub, wash bowl, in a wet basement; or near a swimming pool; and the like.
6. Cleaning – Please see specific recommendations under “Cleaning and Disinfection” on previous page.
7. Do not block any ventilation openings. Install in accordance with the manufacturer’s instructions. The openings should never be blocked by placing the product on a bed, sofa, rug, or other similar surface.
8. Do not install near any heat sources such as radiators, heat registers, stoves, or other apparatus (including amplifiers) that produce heat.
9. DO NOT defeat the safety purpose of the polarized or grounding-type plug. This product is equipped with a three-wire grounding-type plug, a plug having a third (grounding) pin. This plug will only fit into a grounding-type power outlet. This is a safety feature. If you are unable to insert the plug into the outlet, contact your electrician to replace your obsolete outlet.
10. Protect the power cord from being walked on or pinched particularly at plugs, convenience

receptacles, and the point where they exit from the product.

11. Attachments only use attachments/accessories specified by the manufacturer.
12. Use only with the cart, stand, tripod, bracket, or table specified by the manufacturer, or sold with the apparatus. When a cart is used, use caution when moving the cart/apparatus combination to avoid injury from tip-over. 
13. Refer all servicing to qualified service personnel. Servicing is required when the apparatus has been damaged in any way, such as power-supply cord or plug is damaged, liquid has been spilled or objects have fallen into the apparatus, the apparatus has been exposed to rain or moisture, does not operate normally, or has been dropped.
14. Power Sources – This product should be operated only from the type of power source indicated on the marking label. If you are not sure of the type of power supply to your facility, consult your product dealer or local power company. For products intended to operate from battery power, or other sources, refer to the operating instructions.
15. Oxygen Environment – Do not use in an oxygen tent or oxygen chamber. Such use may cause a fire hazard.
16. Lightning – For added protection for this product during a lightning storm, or when it is left unattended and unused for extended periods of time, unplug it from the wall outlet and disconnect the antenna or cable system. This will prevent damage to the product due to lightning and power-line surges.
17. Servicing – Do not attempt to service this product yourself as opening or removing covers may expose you to dangerous voltage or other hazards. Refer all servicing to qualified service personnel.

## IMPORTANT SAFETY INSTRUCTIONS (FRENCH)

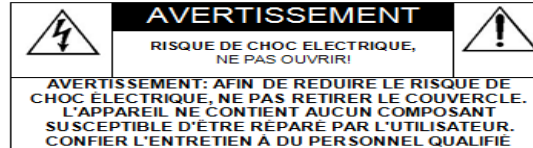
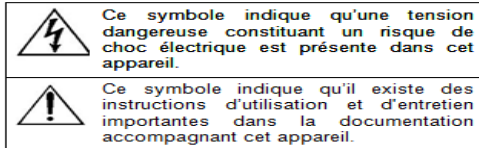

### Danger chute d'objets



AVERTISSEMENT: Afin d'éviter toute blessure, cet appareil doit être solidement fixé au sol/mur conformément aux instructions d'installation. Les télévisions peuvent présenter un risque de heurt

lorsqu'elles sont montées en position élevée. Utiliser uniquement des supports de montage, des bras de support et le matériel approprié de PDi afin d'assurer que la télévision ne tombe pas de sa position de montage. Le non-respect de ces instructions peut causer des blessures ou la mort.

### Pluie et humidité



AVERTISSEMENT: Afin d'éviter les risques d'incendie ou de choc électrique, NE PAS exposer cette télévision à la pluie ou à l'humidité ou l'utiliser dans un endroit humide.

### Environnement d'oxygène



AVERTISSEMENT: Ne pas utiliser dans une tente à oxygène ou chambre à oxygène. Une telle utilisation peut causer un risque d'incendie.

**CONSIGNES DE SÉCURITÉ IMPORTANTES**  
**CETTE INSTALLATION DOIT ÊTRE EFFECTUÉE PAR UN TECHNICIEN QUALIFIÉ ET DOIT ÊTRE CONFORME À TOUS LES**  
**CODES LOCAUX. LIRE ET SUIVRE LES CONSIGNES DE SÉCURITÉ AVANT DE PROCÉDER À L'INSTALLATION.**

- Lire ces instructions. Toutes les consignes de sécurité et d'utilisation doivent être lues avant d'utiliser le produit.
- Conserver ces instructions. Les consignes de sécurité et d'utilisation doivent être conservées pour référence future.
- Respecter tous les avertissements. Tous les avertissements sur le produit et dans les consignes d'utilisation doivent être respectés.
- Suivre toutes les instructions. Tous les avertissements sur le produit et dans les consignes d'utilisation doivent être suivis.
- Ne pas utiliser cet appareil près de l'eau - par exemple près d'une baignoire, d'un lavabo, dans un sous-sol humide, ou près d'une piscine ou similaire.
- Veillez voir les recommandations sous "Nettoyage et Désinfection" à la Page précédente.
- Ne pas obstruer les ouvertures de ventilation. Installer conformément aux instructions du fabricant. Les ouvertures ne doivent jamais être obstruées en plaçant le produit sur un lit, un canapé, un tapis ou toute autre surface similaire.
- NE PAS installer près de sources de chaleur telles que radiateurs, registres de chaleur, poêles ou tout autre appareil (y compris les amplificateurs) qui produit de la chaleur.
- NE PAS neutraliser le dispositif de sécurité de la fiche polarisée ou de terre. Ce produit est équipé d'une prise de terre à trois fils, une fiche ayant une troisième broche (mise à la terre). Cette fiche ne peut s'insérer que dans une prise de courant avec mise à la terre. Il s'agit d'une caractéristique de sécurité. Si vous êtes incapable d'insérer la fiche dans la prise, contacter votre électricien pour remplacer votre prise obsolète.
- Protéger le cordon d'alimentation pour qu'il ne soit pas piétiné ni pincé, en particulier au niveau des fiches, des prises de courant et au point de sortie de l'appareil.
- Accessoires - Utiliser uniquement les attaches/accessoires recommandés par le fabricant.
- Utiliser uniquement avec un chariot, stand, trépied, support ou table recommandé par le fabricant ou vendu avec l'appareil.
- Lorsqu'un chariot est utilisé, faire attention lors du déplacement de l'ensemble chariot/appareil afin d'éviter des blessures en cas de basculement.
- Confier toute réparation à un personnel de service qualifié. Des réparations sont nécessaires si l'appareil est endommagé d'une façon quelconque, par exemple : cordon ou prise d'alimentation endommagé, liquide renversé ou des objets sont tombés dans l'appareil, l'appareil a été exposé à la pluie ou à l'humidité, ne fonctionne pas normalement ou s'il est tombé.
- Sources d'alimentation - Ce produit doit être utilisé uniquement à partir du type de source d'alimentation indiqué sur l'étiquette. Si vous n'êtes pas sûr sur le type d'alimentation de votre domicile, consultez le détaillant de votre produit ou la compagnie d'électricité locale. Pour les produits proposés de fonctionner par piles, ou autres sources d'alimentation, reportez-vous aux consignes d'utilisation.
- Environnement d'oxygène - Ne pas utiliser sous une tente à oxygène ou chambre à oxygène. Une telle utilisation peut causer un risque d'incendie.
- Foudre - Pour une protection supplémentaire pour ce produit lors d'un orage, ou lorsqu'il est laissé sans surveillance et inutilisé pendant de longues périodes de temps, le débrancher de la prise murale et déconnecter l'antenne ou le système de câble. Cela permettra d'éviter tout dommage à l'appareil causé par la foudre et par les surtensions des lignes électriques.
- Entretien - N'essayez pas de réparer ce produit vous-même car l'ouverture ou le retrait des couvercles peut vous exposer à une tension dangereuse ou à d'autres dangers. Confiez toutes les réparations à un technicien qualifié.

## Part I: Installation

This section is for installers

### POWER AND CABLING REQUIREMENTS

For models powered over coax, use only a power source from PDi suitable for use in a healthcare facility. The single coaxial cable out the top/back of the medTAB is used to supply low voltage 28VAC (or 24VDC) and RF signal to the medTAB.

For models powered by ethernet (PoE) use only UL listed power sourcing equipment that offers 60W per port using all 4 pairs for power delivery. The industry uses several different identifiers to indicate the availability of 60W per port, including the following:

- IEEE 802.3bt type 3
- PoE++
- Ultra PoE (UPoE)
- Cisco Universal PoE+ (UPOE+)

Power sourcing equipment typically has a total power output less than needed to power all ports at the full 60W each. PDi medTABs need 60W to meet peak demand, but on average use about half that. So a minimum recommended total power output is 30W x # of ports leading to a medTAB. As example, a 24 port PoE inserter must have at least a 24x30=720W total power output.

PDi recommends the following PoE midspan power inserters which have been tested and UL listed with PDi products:

- 1 port - Microchip Microsemi PD-9601G/AC
- 6 port - Microchip Microsemi PD-9506G/ACDC/M
- 12 port - Microchip Microsemi PD-9512GC/AC or PD-9612GC/AC
- 24 port - Microchip Microsemi PD-9524GC/AC or PD-9624GC/AC

On PDi devices powered over Ethernet, the ethernet cable on top/back of the medTAB is used to supply both power and data. Be sure power is not applied to the coaxial cable entering the medTAB.

### Coax Cable Specifications

When using a central power supply, cable selection is crucial. Due to long coax cable runs encountered in

hospital installations, coax cable employing a solid copper center conductor and copper shield is required. Cable run lengths MUST NOT exceed 150 feet.

Required coaxial cable numbers include the following, which have been tested with coax-powered medTABs and TVs.

- Alpha M4182 (replaced Alpha 9804C) (non-plenum)
- Belden 9248 (non-Plenum)
- West Penn 806 (non-Plenum)
- West Penn 25806 (Plenum)

### CATEGORY CABLE SPECIFICATIONS

PoE models are IEEE 802.3bt compatible. When using a PoE power inserter to apply power to ethernet, you may run up to 328 feet of CAT5e or better.

### INSTALLING AND REMOVING THE MEDTAB

#### Installing a top mounted medTAB on Suspension Arm

This medTAB is designed to attach to a PDi suspension arm that is designed to support the weight of the medTAB. See Document PD196-428 Arm Mounted PDi TV Installation Instructions for additional details as the installation is the same for the medTAB.

1. Remove the 3/4" socket head cap screw (PDISHCS252075) and the retaining washer (PD220-002) from the retainer plate of the medTAB. Discard the washer and place socket head cap screw to the side.
2. Slide the medTAB onto the end of the arm so that the retainer plate rests on top of the arm nose and the hole in the retainer plate aligns with the hole in the arm nose.
3. Secure the medTAB into place with the 3/4" socket head cap screw from step 1.
4. Remove the safety pin from the safety brake pin hole in the suspension arm. Store the safety pin in the nose of the arm for easy access during medTAB removal.
5. Ensure power to the medTAB is disabled. Follow appropriate safety procedures to connect the cables and secure arm covers.

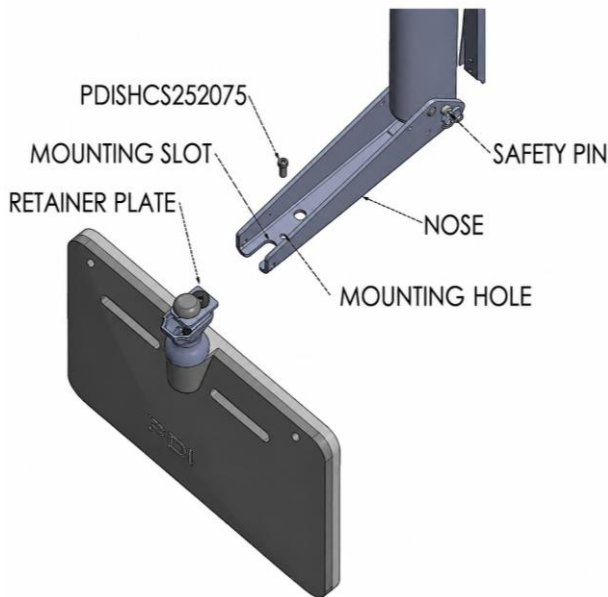
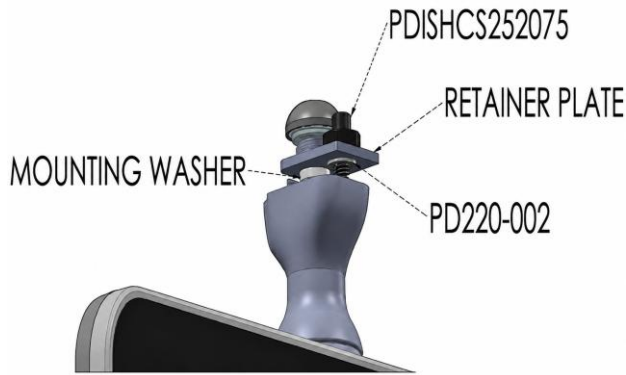

**Arm Recoil Hazard:** The safety brake pin **must remain in the SAFETY BRAKE PIN HOLE** whenever the medTAB is removed from the arm or when the arm is removed from the wall bracket to prevent INJURY from the arm springing open.

**Removing a Top-Mounted medTAB from Suspension Arm**

Follow these steps to remove the medTAB from the arm:

1. Follow the site safety procedures to disable power source to the medTAB. Remove plastic arm cover kits from the nose of the arm.
2. Find the safety pin stored in the nose of the arm. If unable to find the safety pin, contact PDi for a replacement before proceeding
3. Install the safety pin in the safety brake pin hole.
4. Remove the 3/4" socket head cap screw, disconnect the cables, and slide the medTAB off the arm nose. **NOTE:** The 3/4" socket head cap screw is the only hardware that will need to be loosened or removed when removing a medTAB from a PDi suspension arm.

**Installing a Rear Mounted medTAB**

The arm-mounted medTABs from PDi that have been configured for rear mounting can be mounted on a 75mm x 75mm VESA pattern.

Since there are many options for rear mounting, refer to Document PD196-428 Arm Mounted PDi TV Installation Instructions for general mounting instructions. Refer to the specific VESA mounting bracket for additional details.

**Installer Section Complete**

At this point:

- ✓ medTAB is safely mounted
- ✓ Cables are connected
- ✓ Power verified
- ✓ Boot screen confirmed

**Further configuration must be performed by  
authorized Hospital IT personnel.**

**Please Refer Part II of this document to  
Hospital IT staff.**

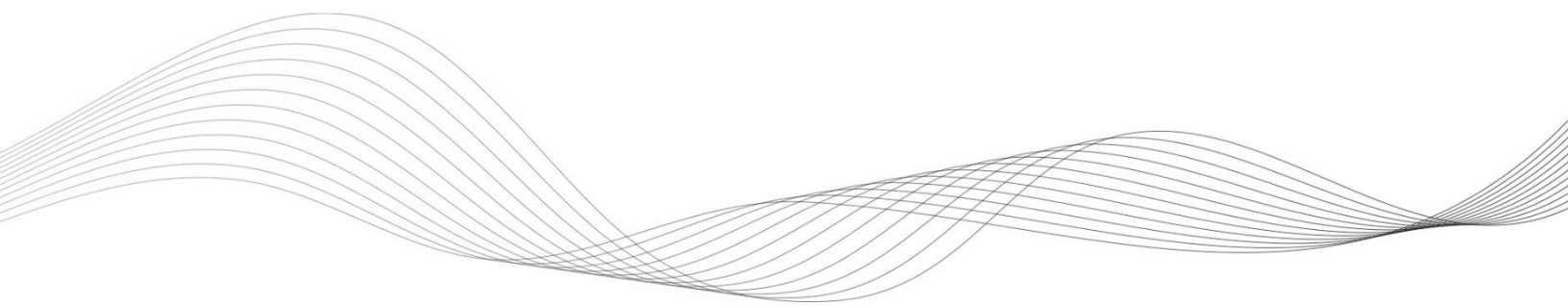

## Part II: Setting up the medTAB

This section is for hospital IT staff

### REMOTE CONTROLS & KEYBOARDS

You can use the medTAB's touchscreen to perform the setup tasks for the medTAB. Alternatively, you can use the PD108-520 programming remote. This programming remote will operate any PDi TV/ TV Box/ medTAB regardless of the product's Bed A/B/C/D setting. Because these remotes have the TV SETUP button to gain full access to the medTAB's menus, patients should not have access to them. PDi offers other remotes designed for patient use.

#### Programming Remote Control

**Power, setup, and the directional buttons will be the main buttons used on the programming remote.** See PDi document PD196-446 for additional information on the PD108-520 remote.

Alternative ways to configure your medTAB include using a keyboard and mouse or a pillow speaker. However, configuring with a pillow speaker is not ideal.

#### Pillow Speakers (Optional)

A 1/4" stereo-style pillow speaker (pendant control) jack is located on the medTAB. This medTAB is designed for 5V pillow speaker voltage and works with a digital pillow speaker that generates digital-style control codes. The medTAB is compatible with universal pillow speaker recognition code set.

To get full use of the features available to patients on PDi medTAB, PDi recommends selecting a pillow speaker with the following buttons: **HOME, BACK, NAVIGATION ARROWS, and OK/SELECT.**

The table below details the function of the main buttons on the programming remote and pillow speakers.

Label	Function
1	Turn selected device on and off
2	Access menus
3	Navigate on-screen menus and adjust settings

Main buttons on pillow speakers

Label	Function
4	Exit to main system dashboard
5	Return to the previous screen or menu level

### A. Programming Remote Control

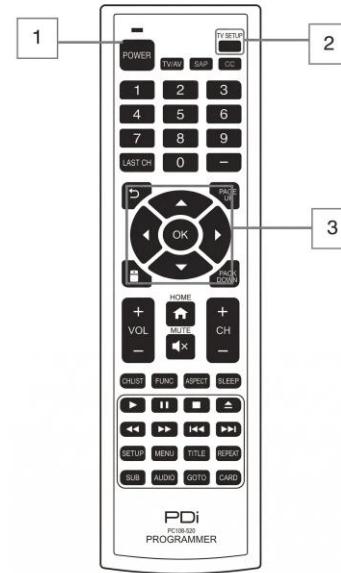

### B. Keyboard and mouse

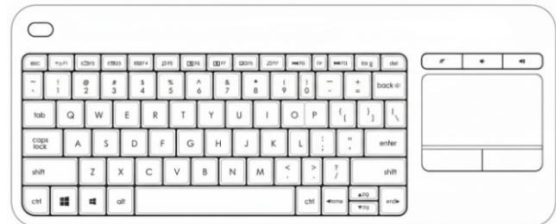

### C. Pillow speakers

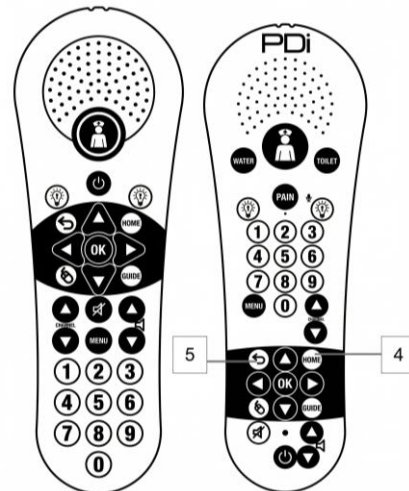

### SETUP WIZARD

The first time the medTAB is powered up, you will be prompted to use the Set-Up Wizard to help with initial set up. Follow the onscreen prompts to navigate through the menus.

#### Optional USB Cloning



If you have already configured another device and created a USB clone file, insert the USB drive and select RESTORE FROM USB. Otherwise, select SKIP.

#### Wi-Fi Selection



If you will be using Wi-Fi for connectivity, select “SELECT WI-FI.” **Guest networks with captive portal (that require the acceptance of terms and conditions before use) should NOT be used.** If you will be using hard wired internet, simply connect the ethernet cable to the jack in the nose of the arm and connect the ethernet cable at the base of the arm to a live ethernet jack.

#### GENiO Project ID



**GENiO SUBSCRIBER:** If you have subscribed to GENiO and been assigned a project ID, enter your GENiO project ID by pressing the keyboard icon and entering your 5-digit project ID and OK. If a valid project ID is entered, a message will appear with the project name. Press the OK button to proceed.

**(optional) Location Setup:** Enter the location of the device by pressing the keyboard icon. This will populate into GENiO to make the device easier to locate and manage within GENiO. Press the OK button to finish. Device will reboot.

**NON-GENiO SUBSCRIBER:** If you are not a GENiO subscriber, simply press the OK button.

#### TV Signal

(this menu only appears for non-GENiO users)



Select type of TV signal in use.

#### Complete Configuration



Finish set up by pressing OK.

## POPULAR CONFIGURATION SETTINGS

### Device Management

To enter device settings:

1. At the home screen, open the Android settings menu with a long press on the medTAB logo in the top left corner of the Main Menu until the PIN entry screen appears.
2. Enter PIN “45066” then press OK. This PIN cannot be changed.

From this screen you can see information about your device, edit GENiO information, access Android settings, and access the setup wizard.

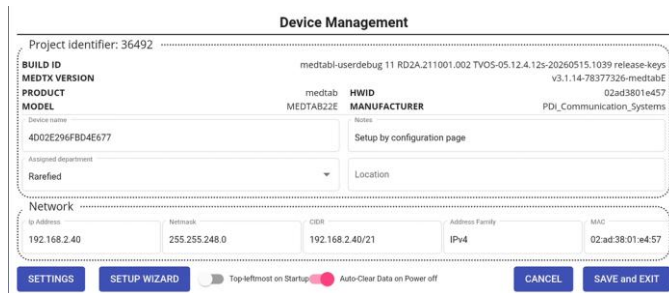

- **Device name** will show in GENiO for this TV
- **Notes** will show in GENiO for this medTAB
- **Assigned department** will set the GENiO department, if one or more are defined
- **Location** will show in GENiO for this medTAB
- **Network** displays network details for the medTAB
- **Settings** provides access to Android settings and information.
- **Setup Wizard** will launch the device setup wizard, allowing you to choose a different configuration or allowing you to register your device to a GENiO project. Select YES when prompted to reset device configuration. This procedure will not reset other device and app settings.

### IPTV SETTINGS

For more information on IPTV setup and use, see PDi Document PD196-460, IPTV App User Guide.

### OPTIONAL SETTINGS

To set up your RF product channels or to make changes to the product settings:

1. Open the TV app on the Main Menu.
2. With the remote, press TV SETUP or bring up the touchscreen menu by pressing anywhere on the screen.

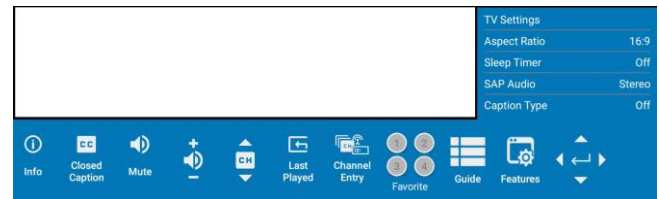

3. Press FEATURES → TV SETTINGS.
4. Enter password 45066 then touch the blue checkmark on the touchscreen or press “OK” on remote.

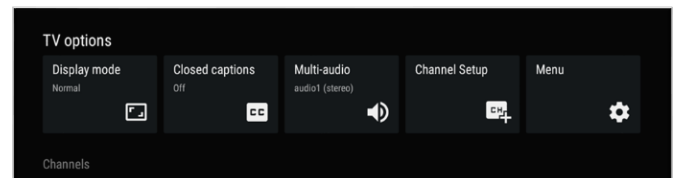

**DISPLAY MODE**

This allows you to change the aspect ratio of the TV app. Note that this setting can also be accessed by device users without a password through the Features menu of the TV app.

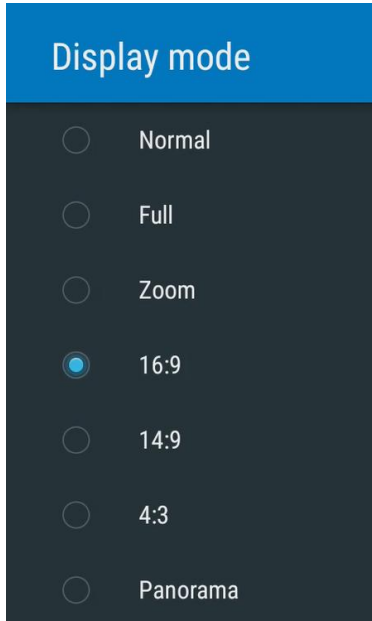

**Closed Captions**

This allows you to turn closed captions on and to change the font size and style of closed captions. Note that this setting can also be accessed by device users without a password through the main TV app navigation and through the Features menu of the TV app.

**Multi-audio / SAP Audio**

The Multi-audio setting allows you to select or manage different audio tracks or sources for the content you're watching. In general, this setting provides flexibility and control over the audio experience, allowing viewers to tailor it to their preferences and needs. SAP (Secondary Audio Program) is typically used for listening to audio in an alternate language. Note that this setting can also be accessed by device users without a password through the Features menu of the TV app.

**CHANNEL SETUP**

This lets you organize your channels. To access the Channel Setup menu:

1. Open the TV app on the Main Menu.
2. With the remote, press TV SETUP or bring up the touchscreen menu by pressing anywhere on the screen and pressing FEATURES → TV SETTINGS.
3. Enter PIN "45066" then touch the blue checkmark on the touchscreen or press "OK" on remote.
4. Select CHANNEL SETUP.

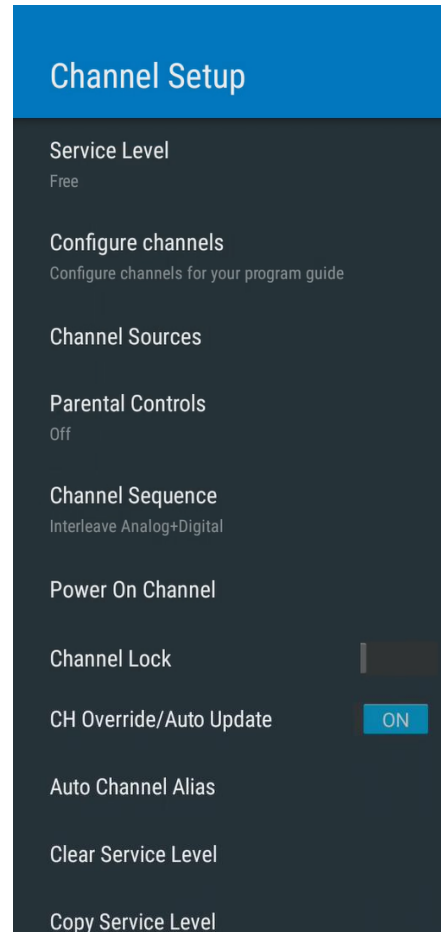

**Service Level**

This medTAB offers three different programmable service levels: FREE, BASIC, AND PREMIUM. Only one service level is usable at a time on an individual TV.

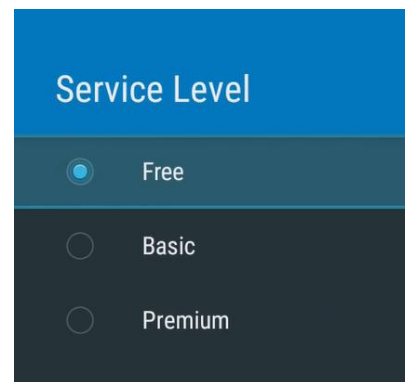

## Configure Channels

This setting allows you to assign channels to one or more service levels. F (Free) B (Basic) P (Premium). Use the touchscreen to select which service level each channel should be assigned to. **You will want to go through Auto Program prior to using this setting.** Open CHANNEL SETUP and go to CONFIGURE CHANNELS.



### Type

The type of channel is listed in the middle of the page with the following abbreviations.

- AC Analog Cable
- DC Digital Cable
- AA Analog Air
- DA Digital Air

On this page, you can also manually change the Service level for individual channels. F stands for FREE, B for BASIC and P for PREMIUM. You can simply use the touchscreen to choose Service levels for different channels.

If you're not looking to restrict access to any channel, it is advisable to set all channels to all three Service levels.

## Channel Sources (Auto Program)

This setting is where you'll find the Auto Program (or Channel Scan) feature. During Auto Program, the medTAB scans each available channel for activity. Channels that display activity are memorized into the selected Service Level.

1. Open the TV application. Touch anywhere on the screen to open the TV's touch controls.
2. Press FEATURES → TV SETTINGS → ENTER PIN "45066" AND PRESS BLUE CHECK MARK → CHANNEL SETUP → CHANNEL SOURCES
3. Press PDi TvInput, change settings if needed.
4. Press Auto Scan button. **NOTE:** Auto scan can take several minutes to complete.
5. Press DONE when Auto Scan is complete.

See RF PRODUCT SETTINGS section for more detailed information.

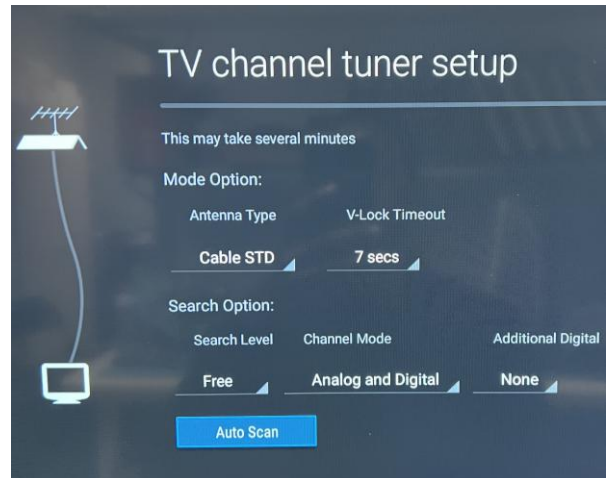
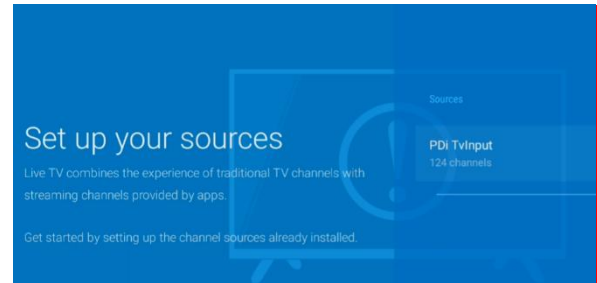

**NOTE:** A programmed service level can also be reprogrammed if desired. Digital channel auto programming may take longer than 10 minutes to complete.

## Mode Option Settings

1. Set the Service Level you are programming (FREE, BASIC, PREMIUM).
2. Set the Antenna Type (Air or Cable) depending upon the healthcare facility's signal style.
3. Leave V-Lock Timeout at 7 secs. The V-Lock Timeout feature can adjust the dwell time at each frequency as the auto-program scans for a valid signal.

## Search Option Settings

1. Set the Search Level you are programming (FREE, BASIC, PREMIUM). Ensure it matches the Service Level Mode setting in step 3.
2. Set the Channel Mode (ANALOG ONLY, DIGITAL ONLY, OR ANALOG AND DIGITAL) depending on the healthcare facility's signal style.
3. Set Additional Digital (NONE OR AIR) depending on the healthcare facility's signal style.
4. Press Auto Scan button. **NOTE:** Auto scan can take several minutes to complete.
5. Press DONE when Auto Scan is complete.

## Deleting Channels from Channel Map

1. Open the TV application. Touch anywhere on the screen to open the TV's touch controls.
2. Press Features → TV Settings → Enter PIN "45066" press blue check mark → Channel Setup → Configure Channels
3. Remove blue checkmarks next to the channel to be deleted for every service level applicable.

## Parental Controls

Parental controls provide the ability to block channels or programs based on their rating. The default setting is off. To enable parental controls,

On the Channel Setup menu, select Parental Controls

1. Create a PIN and confirm your PIN. (The prior PIN is required to change the PIN). If you forget your PIN, you will need to clear TV Settings by going to TV App → TV SETTINGS → Enter Password (4-5-0-6-6) → MENU → SYSTEM → RESET ALL TV SETTINGS. TV will reboot. This will clear all TV Settings.
2. Turn Parent Controls ON with the toggle switch.
  - **Channels Blocked.** Block entire channels from the TV.
  - **Program Restrictions by Rating:** Choose the desired Rating System. Canada, Canada (French), United States, United States (Fim ratings) populate by default. Additional rating systems are

available by pressing SEE ALL RATING SYSTEMS.

- **Block Ratings menu:** Block programs by rating. This can be set based on general settings (HIGH, MEDIUM, LOW) or can be set manually through the Custom menu.

## Channel Sequence

If the facility has both analog and digital channels, this setting allows you to set the order in which they will appear in the channel lineup: ALL ANALOG THEN DIGITAL OR INTERLEAVE ANALOG+DIGITAL. Select based on facility preference.

## Power On Channel

Set the medTAB to power on to a specific channel or to the Last Channel that was on when the medTAB is turned off. POWER ON CHANNEL can be set for each Service Level so long as the Service Level has channels. This feature is useful for hospitals that have a Welcome Channel and wish to have it displayed upon initial use of the medTAB. The patient can then tune to any other available channel.

From the Channel Setup menu:

1. Select POWER ON CHANNEL.
2. Select the SERVICE LEVEL (FREE BASIC, PREMIUM).
3. Select Last Channel or the specific channel desired. **NOTE:** If the selected Service Level shows only Last Channel and no list of channels, that Service Level has no channels assigned to it. Add channels to the Service Level through the Configure Channels menu.

## Channel Lock

This feature allows you to fix the medTAB to a specific channel. For example, this feature may be used if the medTAB is in a common area. With the medTAB tuned to the desired channel, navigate to the Channel Setup menu. Go to CHANNEL LOCK menu item and toggle CHANNEL LOCK switch to ON. To remove the CHANNEL LOCK, toggle CHANNEL LOCK switch again.

## CH Override/Auto Update

CH Override allows any channel to be entered using the medTAB's or the remote's number pad, even if the channel is not memorized in the current Service Level. Toggle the switch to turn CHANNEL OVERRIDE ON/OFF. **NOTE:** the channel must have enough signal strength to be detected by the medTAB's firmware to be added to the existing channel map.

**Auto Channel Alias**

This setting automatically assigns a sequential channel number to the channels in the list. Select the appropriate option and confirm your selection.

- FILL ANALOG GAPS WITH DIGITAL CHANNELS
- RENUMBER ONLY ENABLED CHANNELS,
- RENUMBER ALL CHANNELS
- REMOVE ALL ALIASES.

**Clear Service Level**

This setting clears the channel map for the specified service.

**Copy Service Level**

This setting copies the channel map from one service level to another service level (ie Free copied to Basic).

**medTAB TV Settings**

To access the TV Settings menu:

1. Open the TV app on the Main Menu.
2. With the remote, press TV SETUP or bring up the touchscreen menu by pressing anywhere on the screen and pressing FEATURES → TV SETTINGS.
3. Enter PIN “45066” then touch the blue checkmark on the touchscreen or press “OK” on remote.
4. Choose MENU.

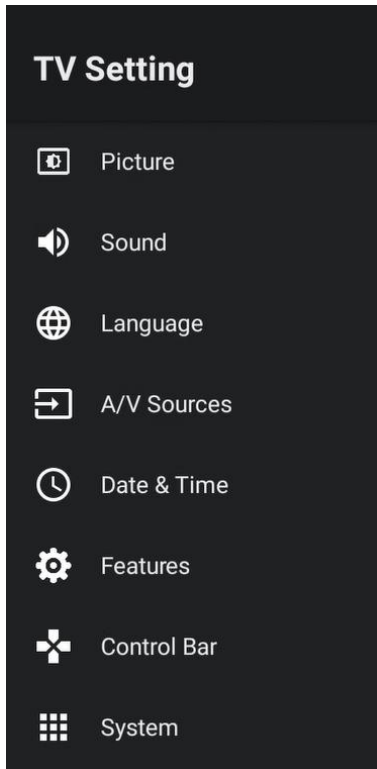

**PICTURE SETTINGS**

**Picture Mode**

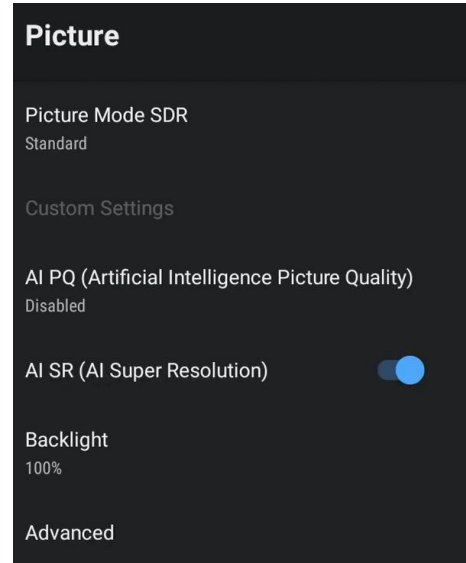

The default is standard picture mode. Or you can change to Vivid, Cinema, Sports, Monitor, Game, or User. User mode allows you to manually adjust picture settings through the custom settings menu where you can manually adjust brightness, contrast, saturation, sharpness, and Hue. All are defaulted to 50%.

**AI PQ (Artificial intelligence picture quality)** default is off

**AI SR (Artificial intelligence super resolution)** default is on

**Backlight**  
Changes the brightness of the display 0-100%. Default is 100%

**Advanced**  
This provides access to additional settings such as color temperature, DNR, DeBlock etc. It is rare that these settings will need to be adjusted.

**SOUND SETTINGS**

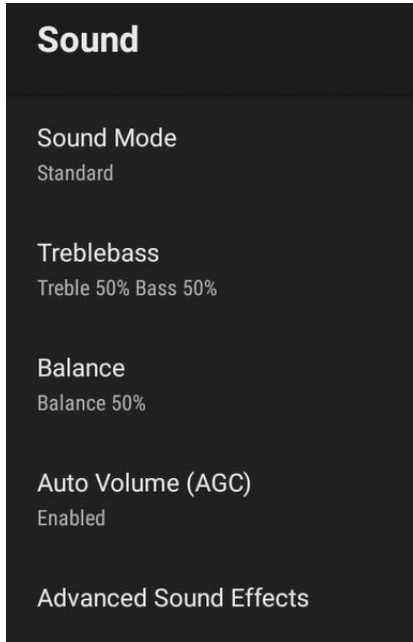

**Sound Mode**

The default is standard sound mode, or you can change to Music, News, Movie, Game, User. User mode allows you to manually adjust five band settings. All are defaulted to 50%.

**Treblebass**

Adjust Treble and Bass. Both default to 50%

**Balance**

Adjust speaker volume left to right.

**Auto Volume**

This makes your medTAB equalize the sound output so that volume levels remain consistent. You can enable or disable this option.

**Advanced Sound Effects**

This provides access to additional settings such as virtual surround and audio source delay (i.e., the delay between sound generation and playback).

**LANGUAGE**

Language settings apply to the system menus only. More than 40 languages are available.

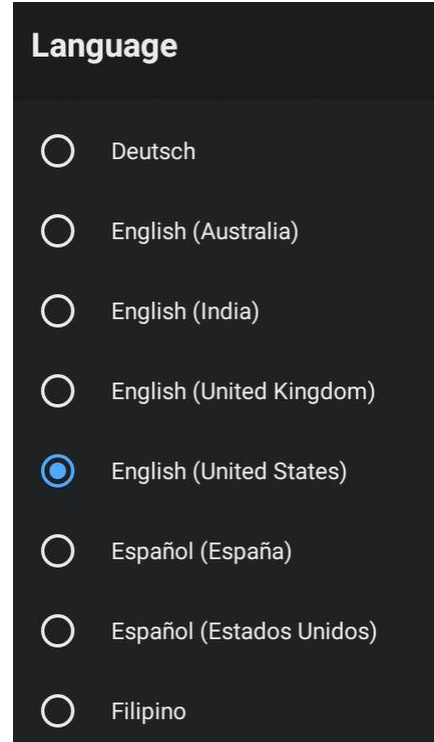

**A/V SOURCES**

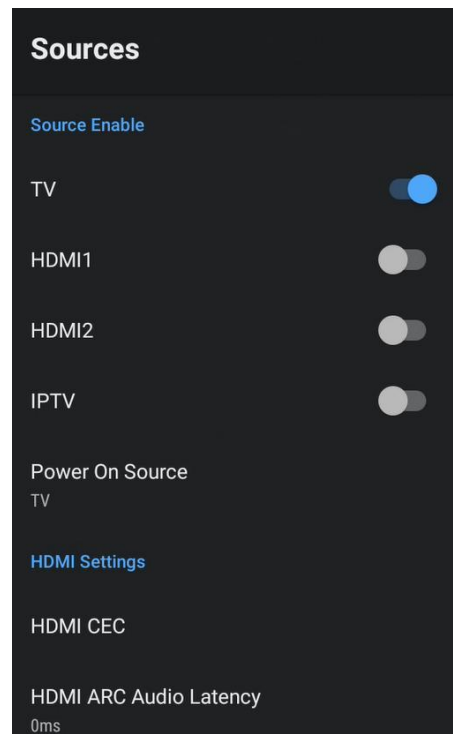

### Source Enable

If you ordered your medTAB with optional HDMI inputs, this menu is where you will enable the source. Each source enabled or disabled.

1. Open the TV application. Touch anywhere on the screen to open the TV's touch controls.
2. Press Features → TV SETTINGS → Enter PIN "45066" press blue check mark → Menu → A/V SOURCES
3. Select each source to change setting between Enable or Disable.

### Power on Source

This option lets you choose which input source (TV, HDMI, or LAST) your screen defaults to when you turn it on.

HDMI CEC and HDMI ARC Audio Latency  
Enable and adjust HDMI CEC settings and ARC control through the HDMI CEC and HDMI ARC Audio Latency menus under the Sources Menu.

### DATE AND TIME

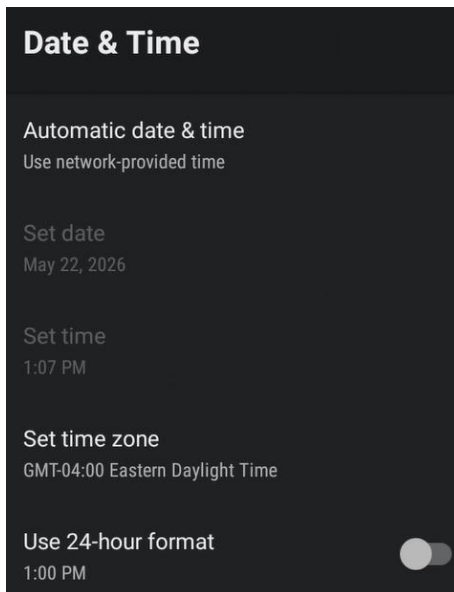

This lets you adjust:

- Automatic date & time
- Set time zone
- 24-hour format

### FEATURES

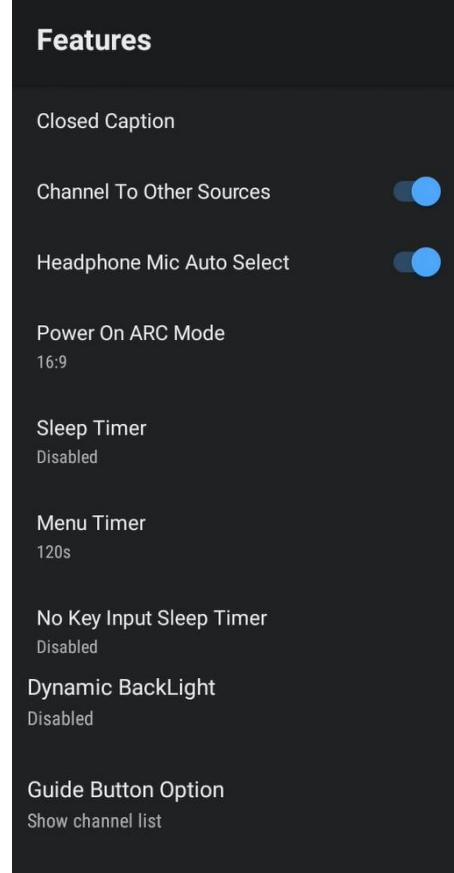

### Channel to Other Sources

When enabled, you can access HDMI sources through the TV channel line up

### Sleep Timer

medTAB will auto power off after the set amount of time. Note that this setting can also be accessed by device users without a password through the main TV app navigation and through the Features menu of the TV app.

### Menu Timer

Set-up menus will automatically close after the defined amount of time. This feature can be disabled, or the default 30 seconds can be changed from 15 seconds to 240 seconds.

## CONTROL BAR

This lets you enable or disable the FAVORITE, GUIDE, and D-PAD buttons on the main TV app navigation pane.

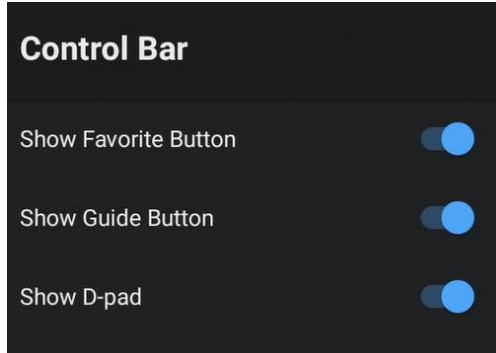

## Security

The default PIN/Password for all menus is 45066. You can change the default PIN for the Product Settings on this menu.

1. From the TV touchscreen menu → Features → TV Settings → Menu → System → Security → Change menu password. NOTE: If the PIN is changed and forgotten, it cannot be recovered. Factory reset will be required.

The PIN to the Android Settings accessed through the Main Menu logo long-press cannot be changed and is 45066.

## Settings

Access to the Android Settings menu

## SYSTEM

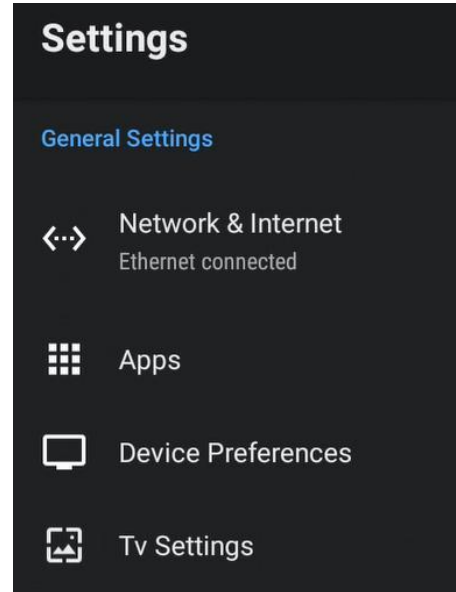
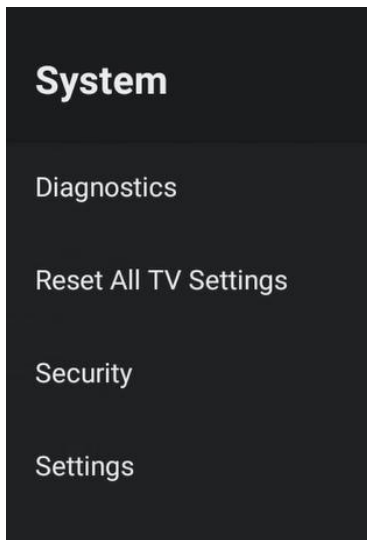

## Diagnostics

This menu provides information on the medTAB's internal operation including power on cause, CCI version, TV version, and hours on. The Diagnostics items are read-only and cannot be changed.

### Reset All TV Settings

Clears TV settings to factory settings. For full device reset, follow these steps.

### Full Factory Reset/ System Recovery

1. Open the Android settings menu with a long press on the medTAB logo in the top left corner of the device until the PIN entry screen appears.
2. Enter the default PIN "45066" then press OK.
3. Press SETTINGS → DEVICE PREFERENCES → ABOUT → FACTORY RESET.
4. Device will reset and reboot.

## USB CLONING

Once you have a PDi medTAB configured the way you want, you can copy these configuration settings to other PDi medTABs. USB Cloning copies most of the medTAB's settings, including channel scan/map, power on channel/volume, channel aliases, min/max volume, source settings, WiFi settings. **NOTE:** USB cloning does NOT copy GENiO project IDs.

On the medTAB you have set up and configured that you want to clone:

1. Open the TV application. Touch anywhere on the screen to open the TV's touch controls.
2. Press FEATURES → TV SETTINGS → ENTER PIN "45066" AND PRESS THE BLUE CHECK MARK → MENU → SYSTEM → SETTINGS → TV SETTINGS → SYSTEM UPDATE AND RESET → USB CLONING.
3. Insert USB drive into USB-A port on front of device.
4. Press SAVE SETTING TO USB.

On the medTAB you want to copy the settings to:

1. Open the TV application. Touch anywhere on the screen to open the medTAB's touch controls.
2. Press FEATURES → TV SETTINGS → ENTER PIN "45066" AND PRESS THE BLUE CHECK MARK → MENU → SYSTEM → SETTINGS → TV SETTINGS → SYSTEM UPDATE AND RESET → USB CLONING.
3. Insert USB drive into USB-A port on front of device.
4. Press RESTORE SETTING TO TV. If no USB drive is found, this option will not be available.
5. From the Restore Setting option, select the file name that you saved your configuration. Cloning will start.

## Firmware Update - USB and Over-the-Air (OTA)

PDi occasionally releases firmware updates for the medTAB. You can apply these updates to your device using a USB flash drive or via OTA. If you upgrade your device using a USB, you will have to reprogram your TV settings.

## OTA Update

1. Open the Android settings menu with a long press on the medTAB logo in the top left corner of the device until the PIN entry screen appears.
2. Default PIN is "45066" then press OK
3. Press SETTINGS → DEVICE PREFERENCES → ABOUT → SYSTEM UPDATE
4. If an update is available, press OK. Device will update and reboot.

## USB Firmware Update

1. Contact PDi for a link to the firmware data file.
2. Copy the file into a blank USB flash drive.
3. Disconnect power from the medTAB. While in a no-power state, insert USB drive to front USB-A port.
4. Reconnect power and the medTAB will update. Be sure to remove the USB drive when the update is complete. Once complete, the device settings must be reprogrammed.

## Change PIN/Passwords for Settings Menus

The default PIN/Password for all menus is 45066. The PIN to the Android Settings accessed through the Main Menu logo long-press cannot be changed. However, you can change the default PIN for the Product Settings.

1. From the TV menu, go to FEATURES → TV SETTINGS.
2. Enter PIN "45066".
3. Press blue check mark, then MENU → SYSTEM → SECURITY → CHANGE MENU PASSWORD. **NOTE:** If the PIN is changed and forgotten, it cannot be recovered. Factory reset will be required.

You can also change the default PIN for the IPTV App Settings. From the IPTV touchscreen menu → FEATURES → APP SETTINGS → Enter PIN "45066". Press enter and scroll down to CHANGE APP SETTINGS PASSCODE. **NOTE:** If the PIN is changed and forgotten, it cannot be recovered. Factory reset will be required.

### Configuration Section Complete

At this point:

- ✓ medTAB rotates safely
- ✓ GENiO works correctly
- ✓ Channels configured correctly
- ✓ Clean audio output

## Troubleshooting Tips

Pillow speaker not acting as expected (ie. press 2 but get a 5. )	<ul style="list-style-type: none"> <li>• Verify that the nurse call system has the correct Personality Block enabled</li> </ul>
Remote not working	<ul style="list-style-type: none"> <li>• Check batteries in remote</li> <li>• Check fluorescent lighting is not causing interference with the TV's IR receiver</li> </ul>
TV channels up or turns off unexpectedly	<ul style="list-style-type: none"> <li>• In rare situations, fluorescent lighting reaching the IR receiver can cause erratic behavior</li> <li>• Relocate the TV away from the light source</li> <li>• Apply opaque tape over the IR sensor</li> </ul>
No picture from external source	<ul style="list-style-type: none"> <li>• Make sure external source is connected properly</li> <li>• Confirm source is not being blocked by Parental Control setting</li> </ul>
Picture, but no sound	<ul style="list-style-type: none"> <li>• Confirm sound is not muted</li> <li>• Confirm no headphones are plugged in</li> <li>• If using an external source, confirm proper connection</li> </ul>
Clone menu does not appear	<ul style="list-style-type: none"> <li>• Verify "USB Media" source is disabled in Sources menu</li> </ul>

## Limited Warranty

PDi Communication Systems, Inc. ("PDi") standard warranty information is found at [pdiam.com](http://pdiam.com). For information regarding authorized servicing and all other information pertaining to this warranty, please contact PDi COMMUNICATION SYSTEMS, INC. at 40 Greenwood Ln, Springboro, Ohio 45066 or phone 800-628-9870 and ask for the PDi ProServices team.