

	MODEL NUMBER: PD168-111	Document Number: PD196-459R1
	Installation Instructions	Page 1 of 2

SCOPE:

To mount a **PD168-111** UPS wall mount with one (1) or two (2) Uninterruptible Power Supplies (UPS) **PD902-067** SOLD SEPARATELY.

The maximum loading on this product is 50 pounds.

The maximum dimensions that this product can hold is: 15" along the wall, 10.25" tall, and 8" from the wall.

NOTE: This loading capacity is only for the product sold by PDi. It is the responsibility of the facility to ensure that the existing mount and the wall are capable of supporting the listed configuration.

TOOL LIST

1. Safety Glasses/Goggles

SAFETY STEPS:

1. Always wear safety glasses/goggles to prevent injury from debris.
2. Follow the installation/removal instructions for your existing products.

BILL OF MATERIAL:

ITEM	PART NUMBER	DESCRIPTION	QTY
1	PD181-925	BRACKET, MOUNTING, UPS, WALL	1
2	PD235-037	STRAP, CINCH, 1" X 36"	2
3	1/4" DIAMETER FLAT HEAD LAG SCREWS	CUSTOMER SUPPLIED LAG SCREWS, GRADE 5 OR BETTER	4
4	1/4" DIAMETER TOGGLE BOLTS	CUSTOMER SUPPLIED TOGGLE ANCHORS	4

PROCEDURE:

STEP 1:

Run the cinch straps, **PD235-037**, (#2) through the slots in the bracket, **PD181-925**, (#1) as shown.

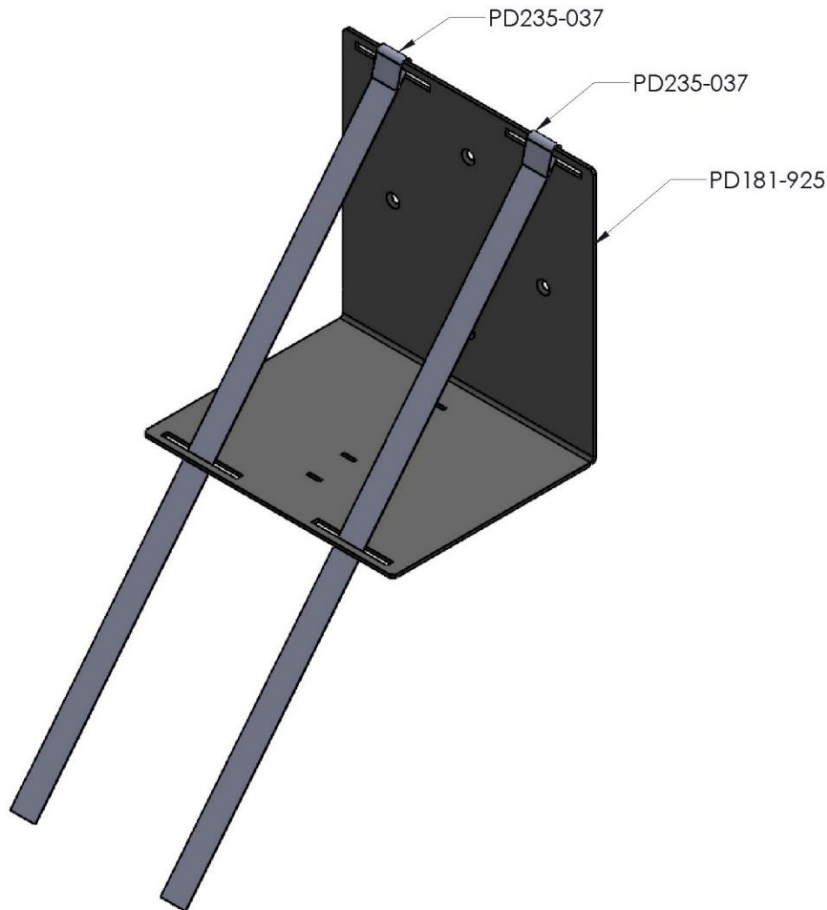

	MODEL NUMBER: PD168-111	Document Number: PD196-459R1
	Installation Instructions	Page 2 of 2

STEP 2:

Mount the bracket, **PD181-925**, (#1) to the wall using either the customer supplied lag screws, or the customer supplied toggle anchors. See the reference hole pattern below.

NOTE: Be sure to follow the manufacturers instructions for using toggle anchors.

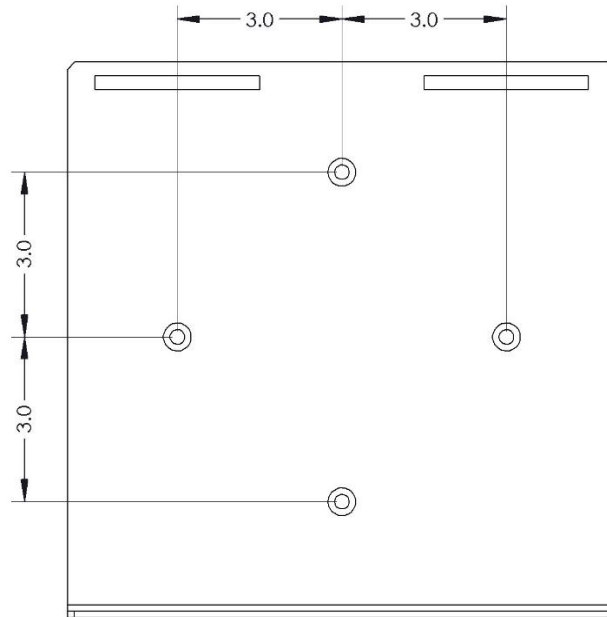

STEP 3:

Slide the UPS, **PD902-067**, inside the cinch straps, as shown and tighten cinch straps. Ensure that the UPS is/are centered on the bracket.

