	MODEL NUMBER: PD168-088	Document Number: PD196-456R1
	200mmx300mm or 400mm VESA Compliant Wall Mount Kit Installation Instructions	

SCOPE:

To mount a TV using a PDI **PD168-088** wall mount kit.
 Note: The maximum capacity for this mount is 50 pounds.

TOOL LIST

1. P1 or P2, Phillips Screwdriver
2. Safety Glasses/Goggles
3. Level

SAFETY STEPS:

1. Always wear safety glasses/goggles to prevent injury from debris.
2. Follow the installation/removal instructions for your existing products.

MOUNTING DISTANCES

25" Minimum from clevis to ceiling for a PDi **65" LED TV**

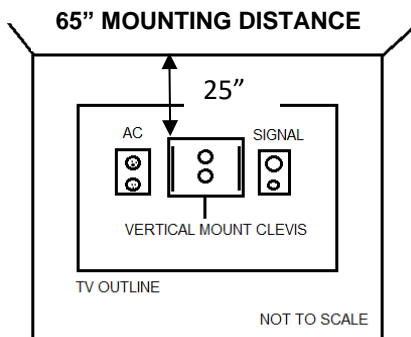

BILL OF MATERIAL:

ITEM	PART NUMBER	DESCRIPTION	QTY
1	PD168-033	200mm WALL MOUNT	1
2	PD181-910	PLATE, ADAPTOR, 200mm TO 300mm OR 400mm	2
3	PDIFWM6	WASHER, FLAT, M6	4
4	PDINILNM6	NUT, MYLOK, M6	4
5	PDIPPHMSM6X116	SCREW, PHILLIPS PAN HEAD, M6-1 x 16MM	4

PROCEDURE TO MOUNT A TV:

STEP 1:

See Step 1 in document **PD196-141** (found on the same webpage) for instructions on how to assemble **PD168-033** (#1).

STEP 2:

Attach the **PD181-910** adapters (#2) to the TV using four (4) **PDIPPHMSM6X116** screws (#5), as shown.

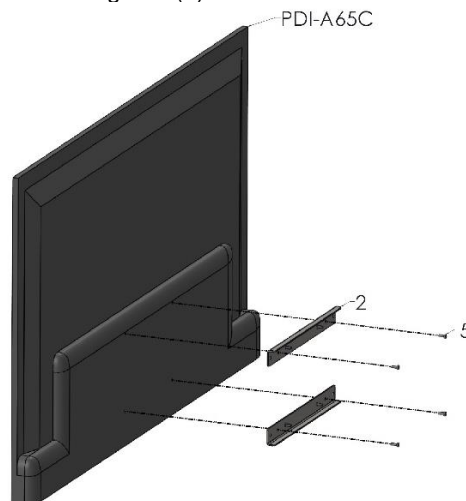

	MODEL NUMBER: PD168-088	Document Number: PD196-456R1
	200mmx300mm or 400mm VESA Compliant Wall Mount Kit Installation Instructions	Page 2 of 2

STEP 3:

Attach the **PD181-672** to the **PD181-910** adapters (#2) using four (4) **PDIFWM6** washers (#3) and four (4) **PDINILNM6** nuts (#4), as shown.

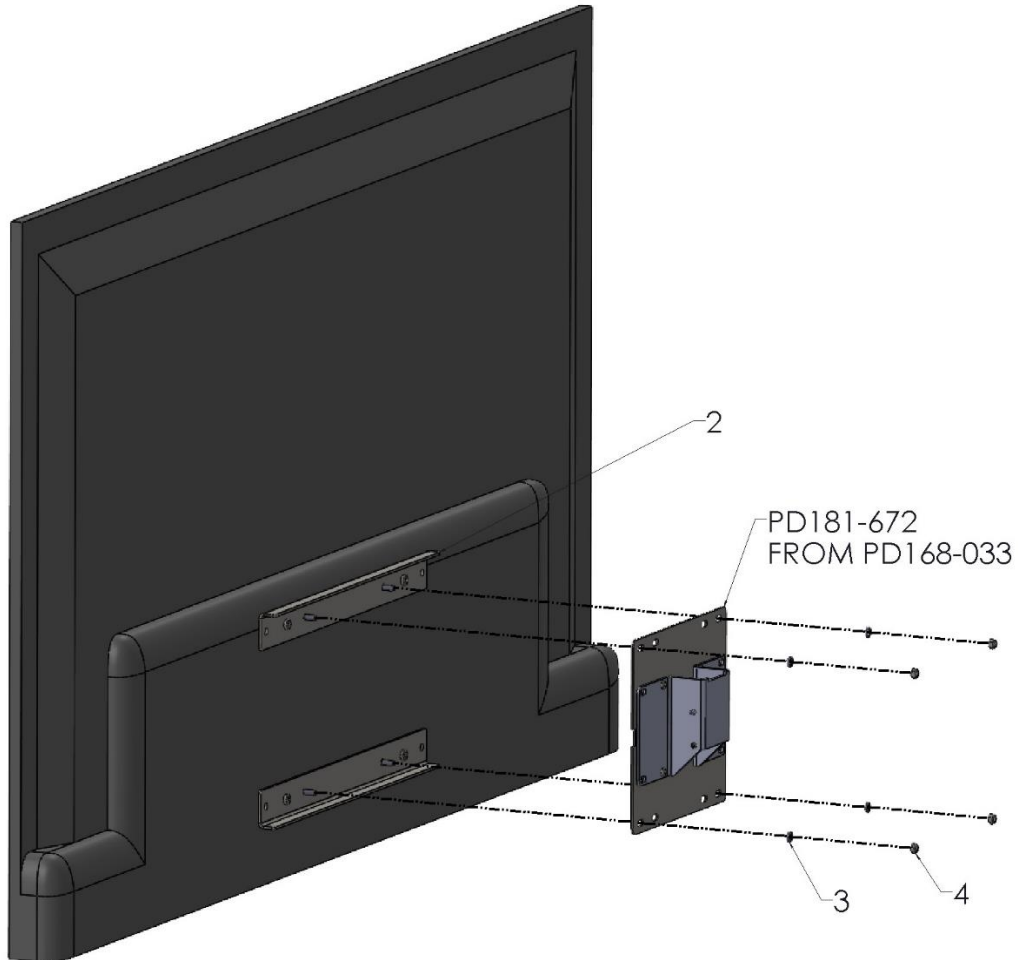

STEP 4:

See Steps 3 & 4 in document **PD196-141** (found on the same webpage) on how to complete the mounting process.