	MODEL NUMBER: PD168-093	Document Number: PD196-452R1
	Installation Instructions	Page 1 of 1

Scope:

To mount a PDi **A32** Television on a mount with 200mm x 200mm VESA pattern.

Notes: The maximum capacity for this bracket is 20lbs, it is the responsibility of the installer to confirm the mount that the bracket is attached to can hold the weight of the bracket and the weight of a PDi **A32** television.

Tool List:

1. P1 or P2 Phillips Screwdriver
2. 1/8" Hex Wrench
3. Safety Glasses/Goggles

Safety Steps:

1. Always wear safety glasses/goggles to prevent injury from debris.
2. Follow the installation/removal instructions for your existing products.

Bill of Material:

Item	Part Number	Description	QTY
1	PD181-918	Plate, Adapter, 200 x 200 VESA to 100 x 200 VESA	1
2	PDIPPHMSM6X110	Screw, Phillips Pan Head, M6-1 x 10mm	4

Procedure:

Step 1:

Remove the old TV from the existing mount and save the four (4) M6 screws.

Note: Be sure to follow any manufacturer instructions on how to remove the TV.

Step 2:

Mount the adapter plate, **PD181-918**, to the back of the PDi **A32** TV as shown using four (4) screws, **PDIPPHMSM6X110**.

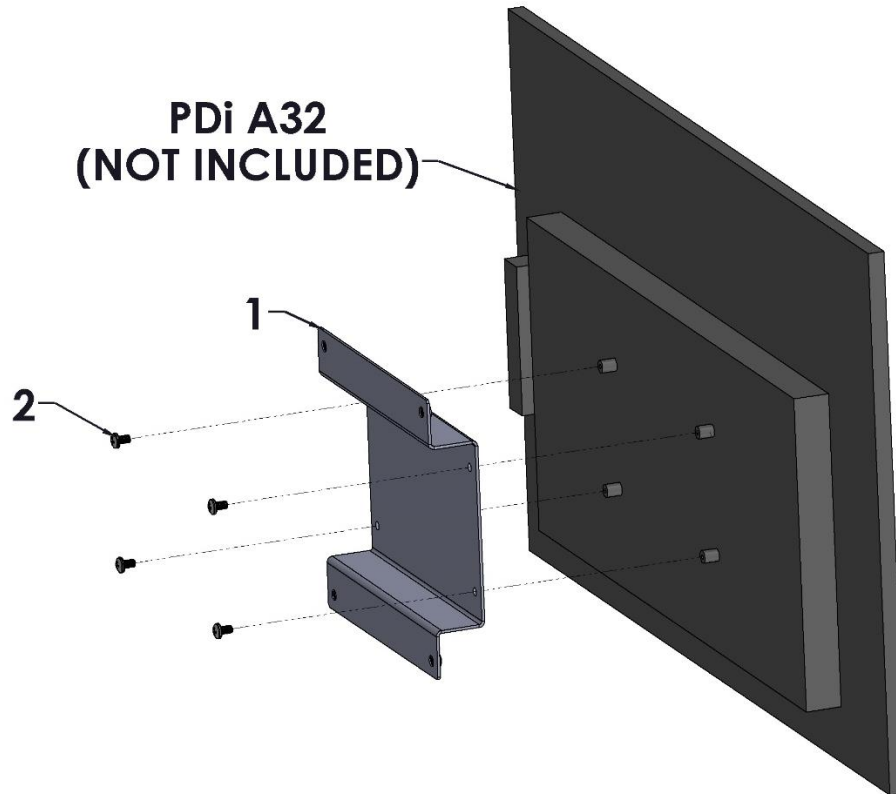

Step 3:

Mount the adapter plate, **PD181-918**, to the existing mount using the four (4) M6 screws that were removed in Step 1.

Note: Be sure to follow any manufacturer instructions on how to attach to the mount.

Limited Warranty

PDi Communication Systems Inc., ("PDi") standard warranty information is found at PDiarm.com. For information regarding authorized servicing and all other information pertaining to this warranty, please contact PDi COMMUNICATION SYSTEMS, INC. at 40 Greenwood Ln, Springboro, Ohio 45066 or phone 800-628-9870 and ask for the PDi ProServices team.