



	MODEL NUMBER: PD153-004-B, C, or G Horizontal Boom	Document Number: PD196-206R6
	Installation and Safety Instructions	Page 1 of 3

	This symbol indicates that dangerous voltage constituting a risk of electric shock is present within this unit.
	This symbol indicates that there are important operating and maintenance instructions in the literature accompanying this unit.

	<div style="border: 1px solid black; padding: 5px; text-align: center;"> CAUTION RISK OF ELECTRIC SHOCK DO NOT OPEN </div>	
CAUTION: TO REDUCE THE RISK OF ELECTRIC SHOCK, DO NOT REMOVE COVER. NO USER SERVICEABLE PARTS INSIDE. REFER SERVICING TO QUALIFIED SERVICE PERSONNEL.		

THIS INSTALLATION SHOULD BE MADE BY A QUALIFIED SERVICE PERSON AND SHOULD CONFORM TO ALL LOCAL CODES. READ AND FOLLOW THE SAFETY INSTRUCTIONS BEFORE ATTEMPTING THIS INSTALLATION.

Note to CATV installer: This reminder is provided to call the CATV system installer's attention to Article 820-40 of the NEC that provides guidelines for proper grounding and, in particular, specifies that the cable ground shall be connected to the grounding system of the building, as close to the point of cable entry into the room as practical.

 **WARNING:** To avoid the hazards of fire or electric shock, DO NOT expose this TV to rain or moisture.

 **WARNING: OXYGEN ENVIRONMENT** DO NOT use in an oxygen tent or oxygen chamber. Such use may cause a fire hazard.

INSTALL ARM & TV

1. Remove pilfer proofing screw, PDIBHSCS252062.
2. Place the horizontal boom's, PD153-004, base pin into the wall bracket. The base pin should seat snug in the wall bracket (Figure 1).
3. Tighten the wall bracket pilfer screw, PDIBHSCS252062, (Figure 1).

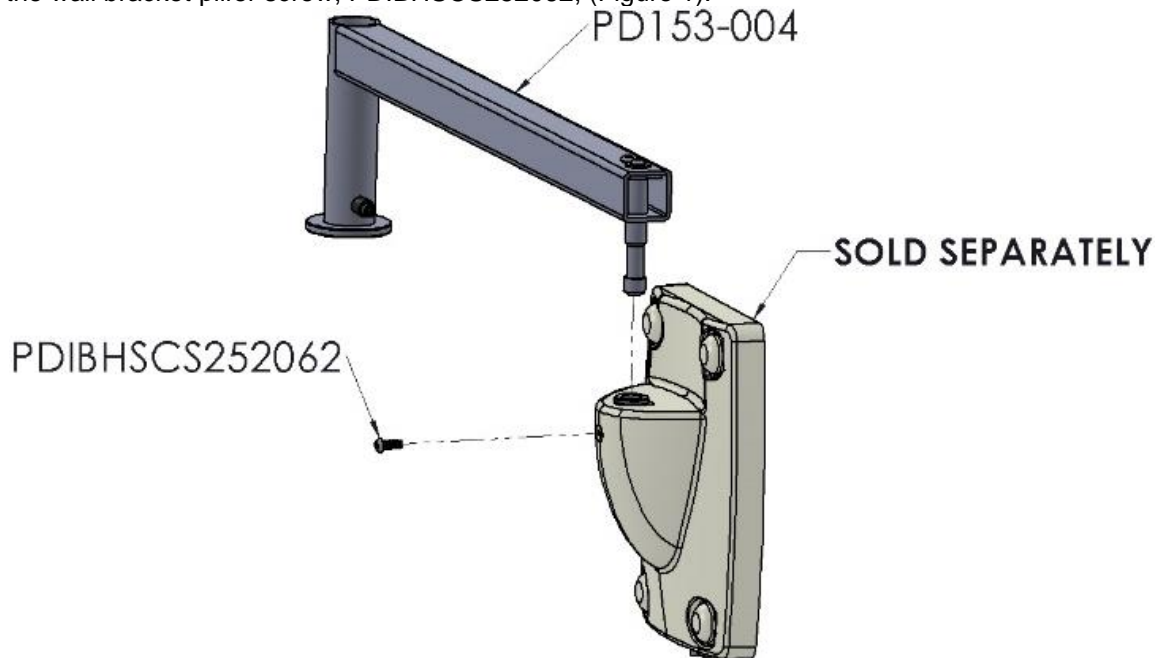

FIGURE 1

4. Slip a slim washer, PDI-586, over the mounting flange as shown (Figure 2). Lubricate the shim washer using the provided silicone grease, PD122-001.
5. Remove the four (4), ¼-20 hex head bolts from the swivel collar, PD188-013.
6. Starting at the wall bracket end of the horizontal boom, PD153-004, drop a fish wire through the horizontal arm section. Be sure to route the wire through the second shim washer, PDI-586, and pull cables through. Feed the cables through the arm according to document PD196-384.

7. Hold the plastic shim washer, PDI-586, against the bottom of the arm section as shown (Figure 2). Be sure it does not overlap the swivel collar. Lubricate the shim washer using the provided silicone grease, PD122-001. Attach the arm assemble to the horizontal boom, PD153-004, using the split collar, PD188-013, and four (4) ¼-20 hex head bolts with LOCTITE® #242 Blue, PD235-002, and tighten the bolts to 10 ft-lbs, as shown.
8. Complete the arm installation per the specific model installation instructions supplied with that arm.
9. Install the anti-rotation bushing, PD242-681 and screw, PDISHCS252075, as shown (Figure 2)
10. Install the TV per the specific model installation instructions supplied with that TV.

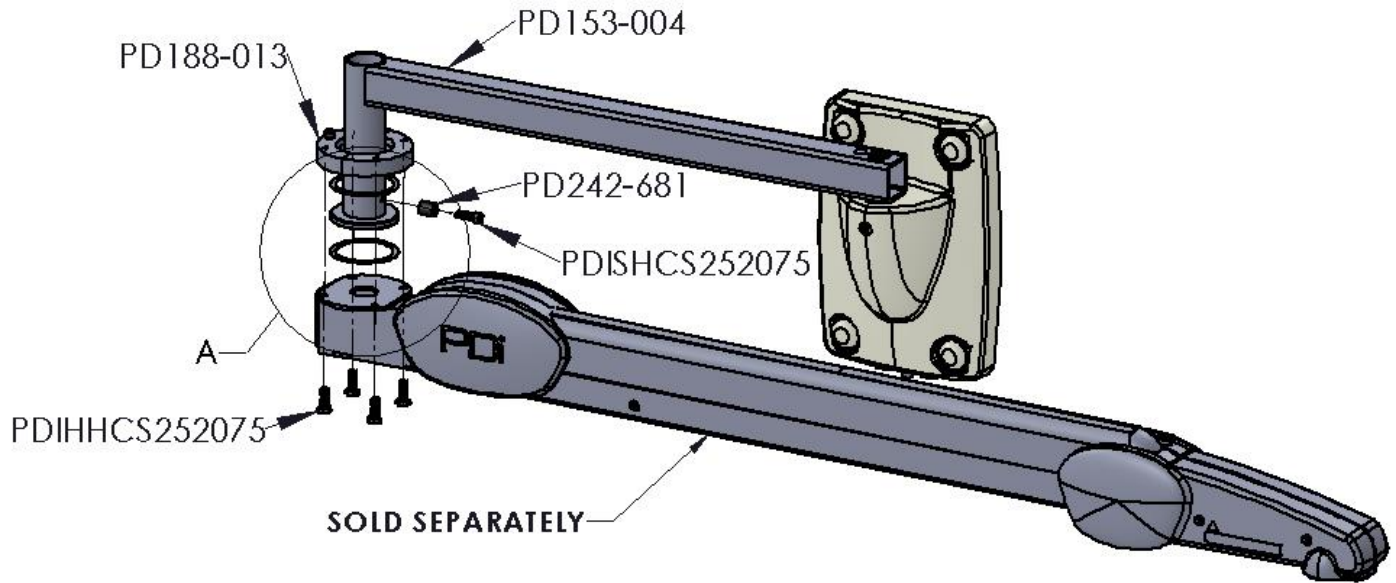
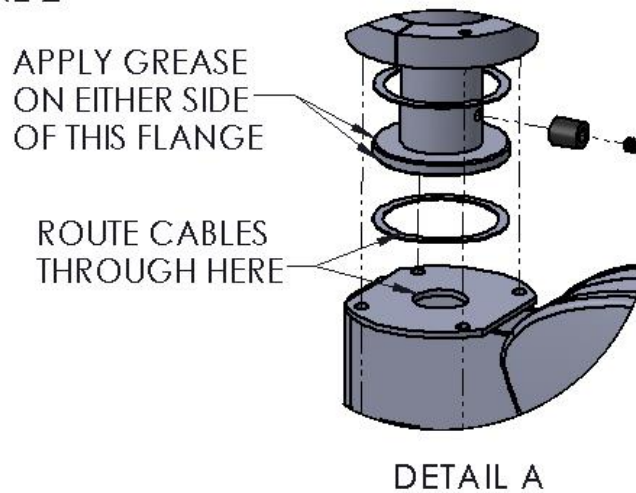



FIGURE 2



	MODEL NUMBER: PD153-004-B, C, or G Horizontal Boom	Document Number: PD196-206R6
	Installation and Safety Instructions	Page 3 of 3

Installation with PDI-179AV or PDI-871 Wall Mount

Envelope Dimensions:

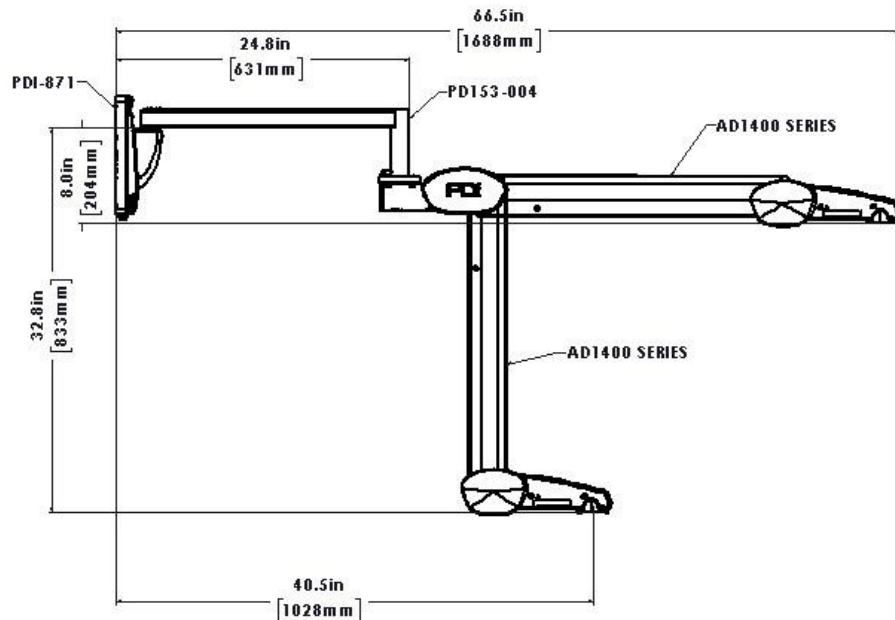

1. Locate the backer plate as indicated in the figure below. Install the backer plate as outlined in the installation instructions, PDi document number PD196-094.

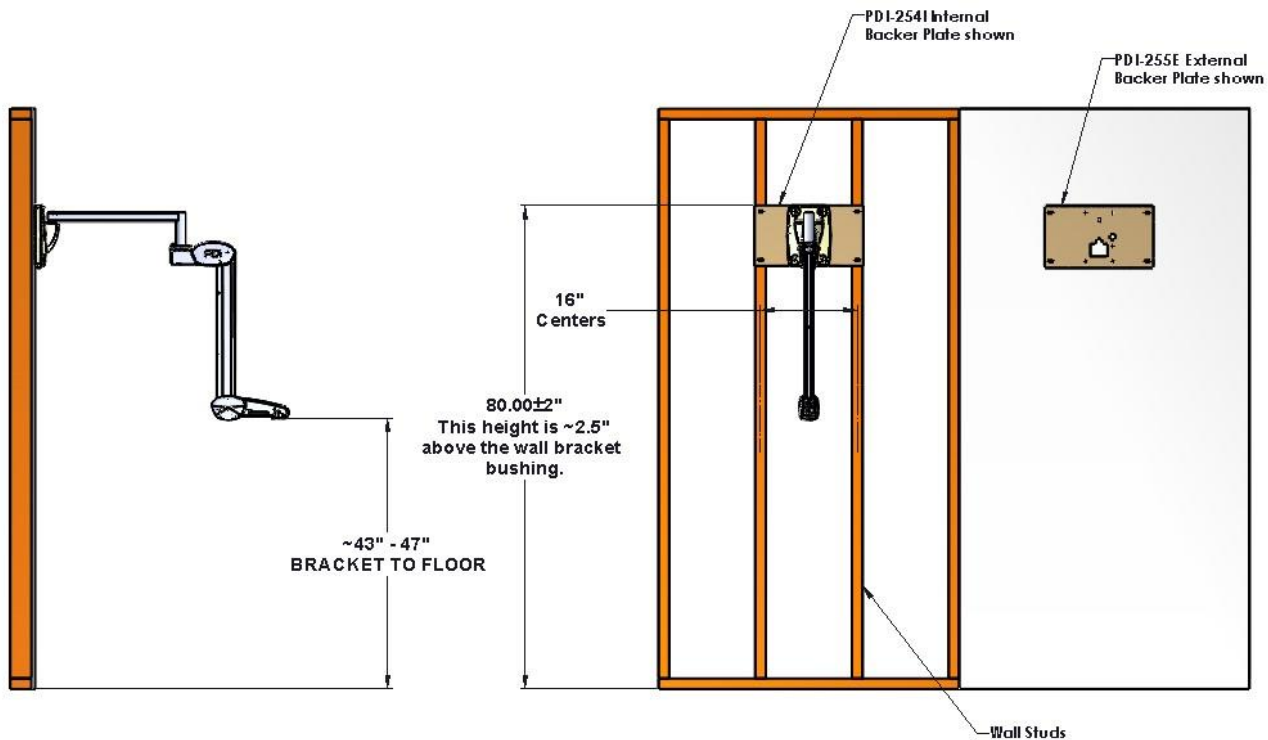

2. Refer to PDi document number PD196-378 for the installation of the PDI-871 Slim Power Wall Mount and document number PD196-396 for the installation of the PDI-179AV wall mount.

Note: Boom Arm may not mate with all models of PDi ceiling mounted arms or all models of TVs. Please confirm with your PDi representative which products will mate with this boom mount. Contact PDi Service for assistance. Ph: 1-800-628-9870, ext. 3486 email: t1service@pdiam.com