	MODEL NUMBER: PD168-065	Document Number: PD196-431R1
	Installation Instructions	Page 1 of 2

Scope:

To Mount a PD168-065 J-Hook Mount to a **PDI-A24A**, **PDI-A32A**, or **PDI-A43A** TV in a **PDI-179** or **PDI-179AV** wall mount.

Note: The maximum capacity for this mount is 32 pounds.

Tool List:

1. P1 or P2 Phillips Screwdriver
2. 1/8" Hex Wrench
3. Safety Glasses/Goggles

Safety Steps:

1. Always wear safety glasses/goggles to prevent injury from debris.
2. Follow the installation/removal instructions for you existing products.

Bill of Material:

Item	Part Number	Description	QTY
1	PD168-065	J-Hook Articulating Mount	1
2	PDIPPHMSM6X110	Screw, Phillips Pan Head, M6-1 x 10mm	4

Procedure:

Step 1:

Mount the wall mount, **PDI-179** or **PDI-179AV**, to the wall following the installation instructions included with the mount, (**PD196-047** or **PD196-393**).

Step 2:

Attach the J-Hook mount, **PD168-065**, (#1) to the TV using four (4) screws, **PDIPPHMSM6X110**, for **PDI-A32A** and **PDI-A43A** TVs as shown below. Be sure to align the correct slots on the J-Hook mount, **PD168-065**, with the VESA pattern on the back of the TV, see reference dimensions below.

Note: Use customer supplied M-4 screws to mount a **PDI-A24A** TV.

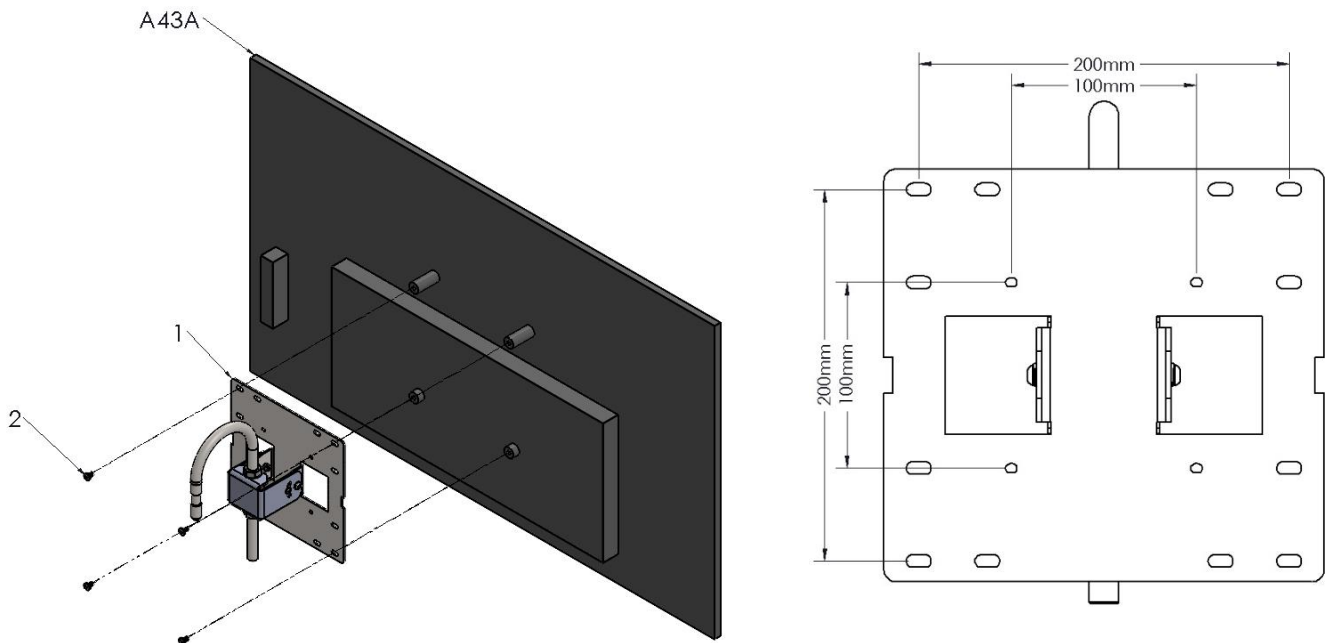

	MODEL NUMBER: PD168-065	Document Number: PD196-431R1
	Installation Instructions	Page 2 of 2

Step 3:

Seat the J-Hook Mount, **PD168-065**, (#1) into the wall mount, **PDI-179** or **PDI-179AV**, and tighten the pilfer proof screw.

Step 4:

To adjust the tilt of the TV, support the weight of the unit and loosen both adjustment screws, one on each side shown below, using a 1/8" hex wrench and adjust to the desired tilt. Tighten the adjustment screws down once the desired tilt has been achieved until the TV remains in place.

Note: Only loosen the adjustment screw! Loosening the non-adjustment screws could cause the TV to fall.

