	MODEL NUMBER: <b>PD168-242</b>	Document Number: PD196-402R2
	300x400 VESA Adapter Kit	Page 1 of 2

**Scope:**

To mount a TV using a PDI PD168-242 Wall Mount Kit, to existing wall mounts.

Note: The maximum capacity is driven by the maximum capacity of the existing 100x100 VESA mount.

**Tool List:**

1. P1 or P2, Phillips Screwdriver
2. Safety Glasses/Goggles
3. Level

**Safety Steps:**

1. Always wear safety glasses/goggles to prevent injury from debris.
2. Follow the installation/removal instructions for your existing products.

**Bill of Material:**

ITEM	PART NUMBER	DESCRIPTION	QTY
1	PD181-672	200mm TO 100mm ADAPTER PLATE	1
2	PD181-825	50" TV MOUNTING BRACKET	4
3	PDIFW10	#10 FLAT WASHER	4
4	PDIPPHMSM4X76	M4-.7 X 6mm PPHMS	4
5	PDIPPHMSM6X110	M6 X 1 10mm PHILLIPS SCREW	4
6	PDIPPHMSM6X18	M6 x 1 8mm PHILLIPS SCREW	4

**Step 1:**

Attach the four (4) **PD181-825** Adapter Brackets (#2) to the back of the TV using four (4) M6 screws, **PDIPPHMSM6X110**, (#5) leave screws finger tight.

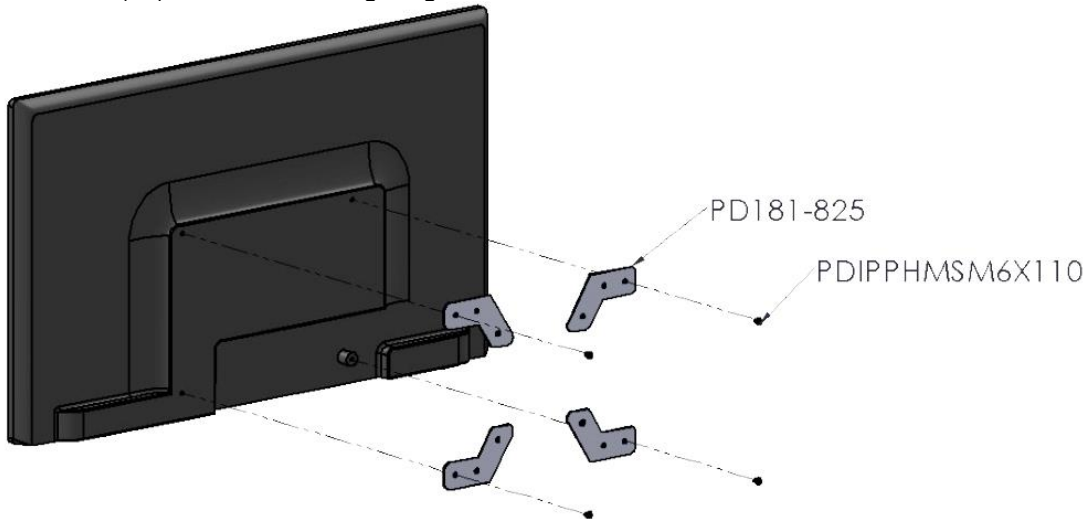

	MODEL NUMBER: <b>PD168-242</b>	Document Number: PD196-402R2
	300x400 VESA Adapter Kit	Page 2 of 2

**Step 2:**

Attach the Adapter Plate, **PD181-672**, (#1) to the existing 100x100mm VESA mount using four (4) M4 screws, **PDIPPHMSM4X76**, (#4) and four (4) internal tooth washers, **PDIITLW10**, (#3). Make sure the existing mounting bracket is attached to the side of the chosen plate with the four round ends of the M4 inserts. The side with the four hex ends will go toward the back of the set.

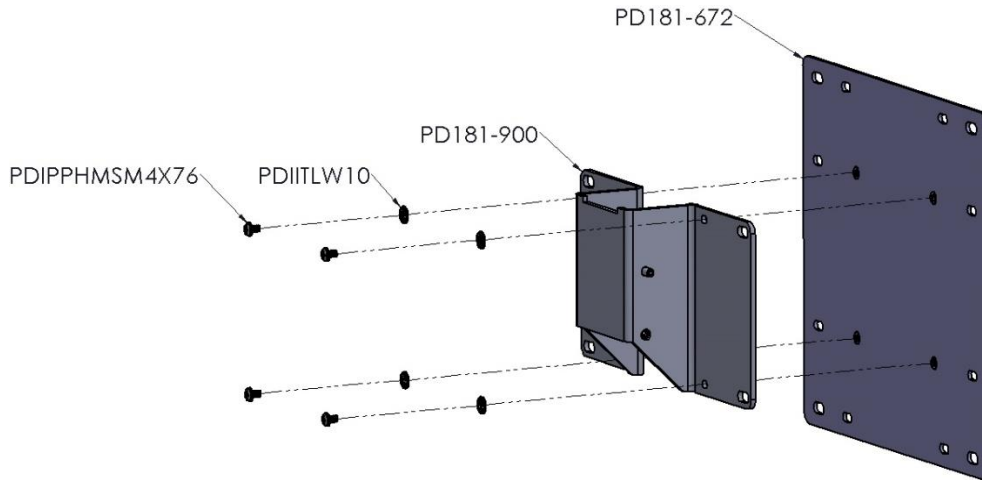

**Step 3:**

Attach part previously assembled on Step #2 to TV using four (4) M6 screws, **PDIPPHMSM6X18**, (#6).

**VESA PATTERNS:**

- 100MM X 100MM WITH M4 THREADS
- 100MM X 200MM FOR M5 FASTENERS
- 200MM X 200MM FOR M6 FASTENERS

