	MODEL NUMBER: PDI-886 & PDI-886WIDE	Document Number: PD196-189R3
	Installation Instructions for Floor Mounts	Page 1 of 2

Scope:

Instructions for installing the PDI-886 & PDI-886WIDE Floor Mounts.

For more detailed anchoring instructions, please see document PD196-061, which can be downloaded from the Document Library on PDI's website.

NOTE: The mounting anchors (3/8 diameter) are not supplied by PDI. The required mounting anchors must meet local building code requirements.

Tool List:

1. Safety glasses/goggles
2. 1/8" hex key (for the pilfer proofing screw).
3. Concrete drill
4. Particle mask that is rated for concrete dust.

Safety Steps:

1. Always wear safety glasses/goggles and particle mask to prevent injury from debris.
2. Follow the installation/removal instructions for you existing products.

PROCEDURE:

Step 1:

Locate and lay out the bolt pattern for the mounting anchors.

Step 2:

Install anchors. Follow all manufacturer's instructions for the installation of the chosen mounting anchors.

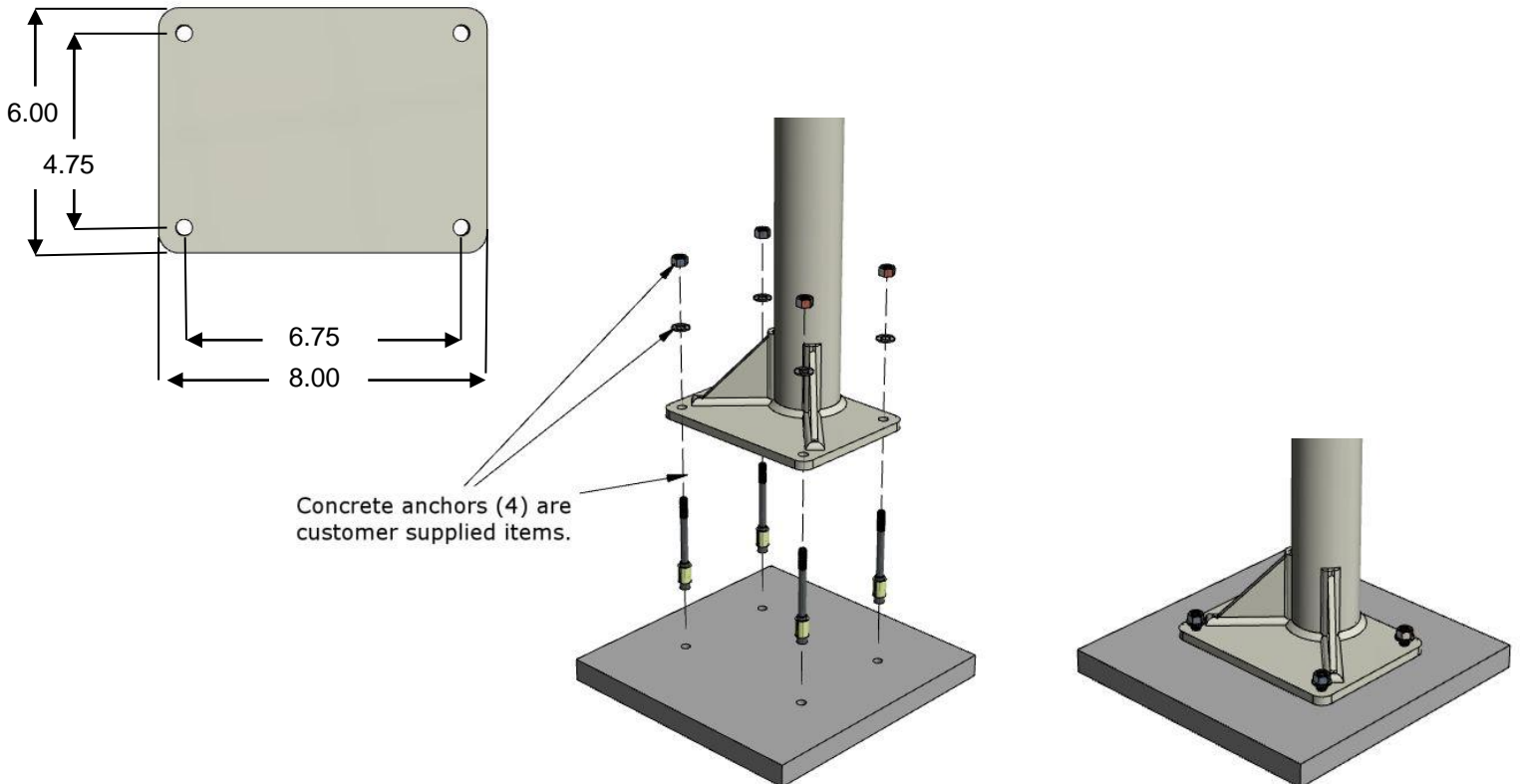

	MODEL NUMBER: PDI-886 & PDI-886WIDE	Document Number: PD196-189R3
	Installation Instructions for Floor Mounts	Page 2 of 2

Step 3:

Use the 1/8" hex key to remove the pilfer proofing screw and spacer.

Step 4:

Ensure the holes in the floor mount for the spacer and pilfer screw are still aligned and install the arm (sold separately) into the floor mount, taking care to properly align the base pin with the bushing, to prevent damage to the bushing during installation.

Step 5:

Use the 1/8" hex key to reinstall the pilfer proofing screw and spacer. Rotate the arm from side to side to verify that it moves smoothly and does not bind on the pilfer proofing screw. Lift up on the arm to confirm that the arm cannot be removed while the pilfer proofing screw is installed. (If the arm can be removed, confirm the holes for the spacer and pilfer screw are aligned and the pilfer screw is inserted far enough without locking the arm from rotating.)

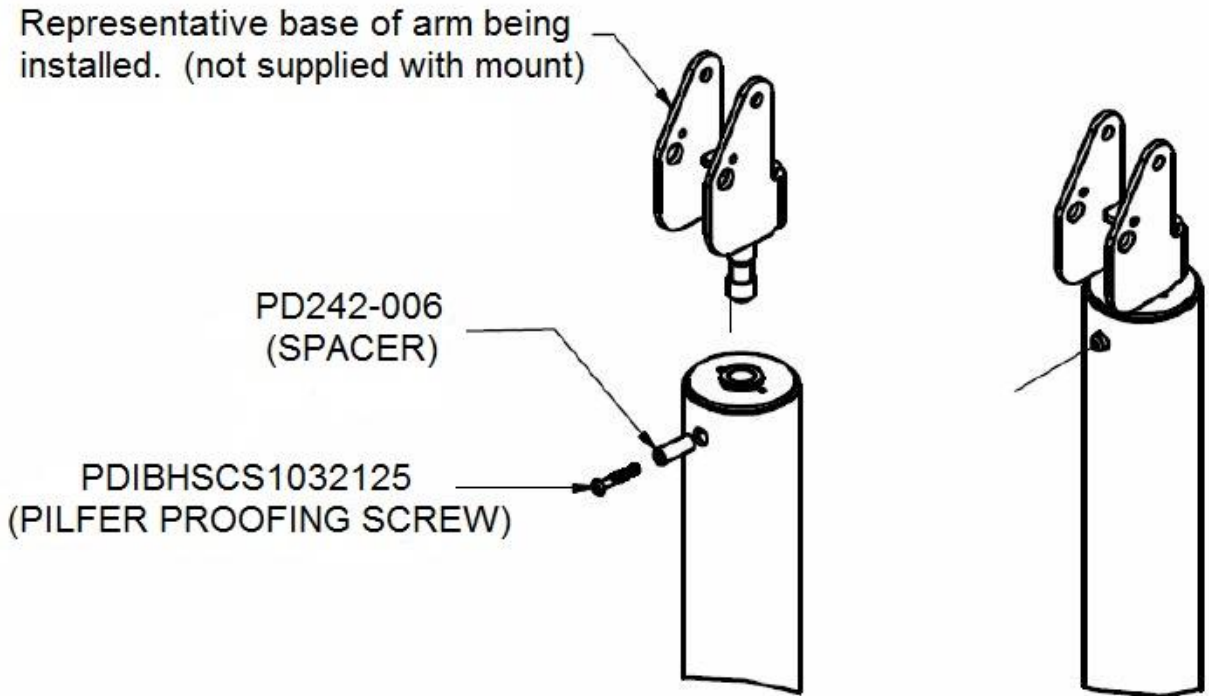

Bolt pattern for the Wide Base Floor Mount

