

1408 PDi Arm

SPECIFICATIONS

Part Number: PDI-AA1408-CB

68" reach arm, supports 8 lbs. (3.6 kg), base pin mount. Includes Coax + Cat6 (ENET) cables

NOTE: PDi arms are designed and built to support a certain load capacity. Use of the arm with any weight other than what is specified is NOT recommended.



Built by PDi for UL healthcare-grade standards



Designed, tested, and assembled in the U.S.A.

Antimicrobial Coatings. Only available in cream

OPERATING ENVELOPE

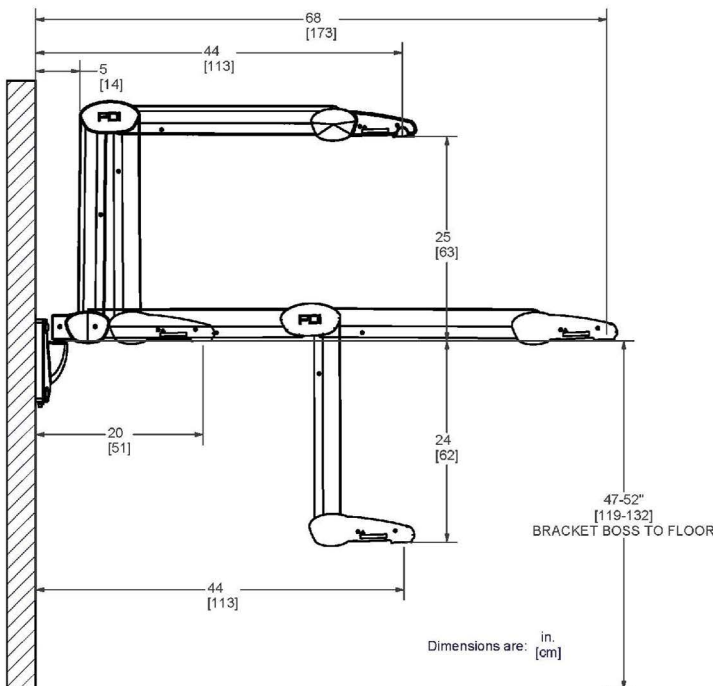

WARNING: Do NOT use for personal lifting assistance or as a handrail.

Features

- UL-Listed
- Nitrogen Gas Cylinder Lift Design
- Anti Recoil Design with Safety Pin
- Swivel Safety Features
- Removable Cable Shields
- Antimicrobial Coating
- Base Pin Mount
- Coax and Cat6 Ethernet Cables

Specifications

- Weight Capacity 8 lbs. (3.6 kg)
- Reach 68" (173 cm)
- Arm Weight 16 lbs. (7.3 kg)
- Arm Rotation 180°
- Display Pan 270°
- Display Tilt +/- 15°

Ask about a variety of ways to mount this arm at the patient bedside or chair, and options for low-voltage power supply. US-based PDi manufactures complete solutions for healthcare.

CALL NOW 800.628.9870