	MODEL NUMBER: PD168-075	Document Number: PD196-421R1
	AA1400 Vertical Stop Kit Installation Instructions	Page 1 of 3

INTRODUCTION

The PD168-075 Vertical Stop Kit is designed to provide additional wall clearance for the 1400 Series arm when in the folded position. Increased clearance is particularly helpful to allow the arm to be installed beneath a head wall light or other obstruction.

INSTALLATION

Included Hardware

- 1 each; **PD202-001** – Disc, Vertical Stop, 2.00" DIA, PDI-1400 ARM
- 1 each; **PD202-002** – Disc, Vertical Stop, 1.63" DIA, PDI-1400 ARM
- 1 each; **PD202-003** – Disc, Vertical Stop, 1.38" DIA, PDI-1400 ARM
- 1 each; **PDIBHSCS1032200** – Screw, #10-32UNF x 2.00", Button Head Cap
- 1 each; **PDIBHSCS103275** – Screw, #10-32UNF x 0.750", Button Head Cap
- 1 each; **PDINILN1032**, – Nut, Nylon Lock, #10-32UNF

NOTE: Before moving the arm make sure a TV is mounted securely, or the safety pin is in place. See Cover Installation Instructions (**PD196-379**) for how to remove the nose cover, and Installation Instructions (**PD196-380**) for how to install the safety pin.

1. With the arm installed in the wall bracket, pull the arm forward away from the wall to allow space to install the vertical stop.
2. Reference Figure 1 to determine which Vertical Stop is needed to achieve the desired clearance.

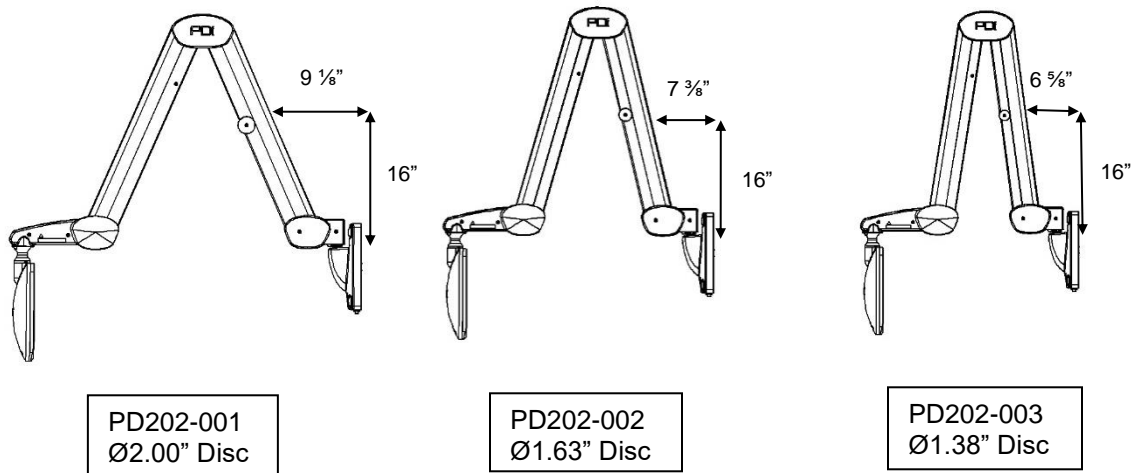



Figure 1: Clearance Options

	MODEL NUMBER: PD168-075	Document Number: PD196-421R1
	AA1400 Vertical Stop Kit Installation Instructions	Page 2 of 3

3. Check the Stop Mounting Hole to see if there are screws already present. (See Figures 2&3)

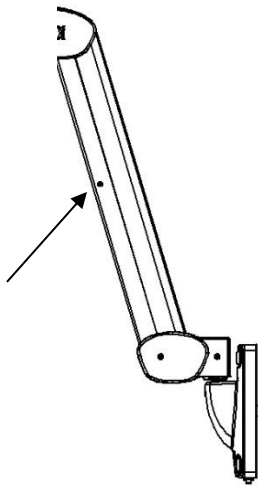

Figure 2: Screw in Stop Mounting Hole

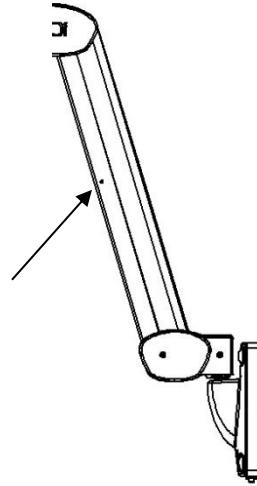

Figure 3: No screw in Stop Mounting Hole

4a. If screws are present, remove **ONE**, of the screws.

NOTE: Removing both screws will require sending the arm to the PDI Service Department for repair. This repair is not covered under warranty.

Attach the desired Vertical Stop with the 0.750" screw, into the Stop Mounting Hole, and tighten to 30 IN-LBS. **Do not overtighten.** (See Figure 4)

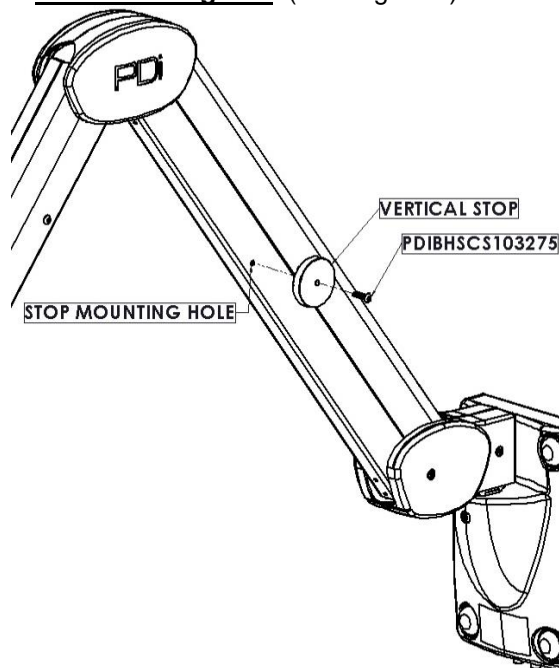



Figure 4: Vertical Stop Secured with **PDIBHSCS103275**

	MODEL NUMBER: PD168-075	Document Number: PD196-421R1
	AA1400 Vertical Stop Kit Installation Instructions	Page 3 of 3

- 4b. If screws are not present in the Stop Mounting Hole, attach the desired Vertical Stop with the 2.00" screw and Nylon Lock Nut into the Stop Mounting Hole and tighten to 30 IN-LBS. **Do not overtighten.** (See Figure 5)

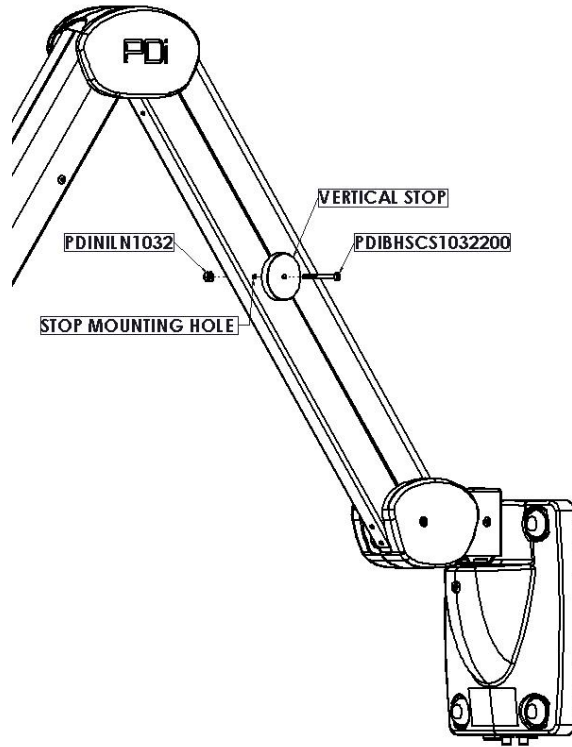

Figure 5: Vertical Stop Secured with **PDIBHSCS1032200** & **PDINILN1032**

5. Cycle the arm and confirm sufficient clearance – if not, use next size larger disc.

WARRANTY

PDi Communication Systems Inc., ("PDi") standard warranty information is found at pdiam.com. For information regarding authorized servicing and all other information pertaining to this warranty, please contact PDi COMMUNICATION SYSTEMS, INC. at 40 Greenwood Ln, Springboro, Ohio 45066 or phone 800-628-9870 and ask for the PDi ProServices team.