



PD251-047

Universal Android Module Kit
(Shown with optional Wi-Fi)

Document Number PD196-370R3

Copyright, Trademarks, and Disclaimer

	This symbol indicates that dangerous voltage constituting a risk of electric shock is present within this unit.
	This symbol indicates that there are important operating and maintenance instructions in the literature accompanying this unit.

	CAUTION	
RISK OF ELECTRIC SHOCK, DO NOT OPEN!		
CAUTION: TO REDUCE THE RISK OF ELECTRIC SHOCK, DO NOT REMOVE COVER. NO USER SERVICEABLE PARTS INSIDE. REFER SERVICING TO QUALIFIED SERVICE PERSONNEL		



Overhead Falling Hazard

WARNING: To prevent injury, this apparatus must be securely attached to the floor/wall in accordance with the installation instructions.

TV can pose a striking hazard when mounted at an elevated position. Use only PDi mounting brackets, support arms, and appropriate hardware to assure TV will not fall from the mounted position



Rain and Moisture

WARNING: To avoid the hazards of fire or electrical shock, DO NOT expose this television to rain or moisture.



Oxygen Environment

WARNING: Do not use in any oxygen tent or oxygen chamber. Such use may cause a fire hazard.

Note to Cable TV Installer

This reminder is provided to call the cable TV system installer's attention to Article 820-40 of the National Electrical Code. The code provides guidelines for proper grounding and in particular specifies that the cable ground shall be connected to the grounding system of the building, as close to the point of the cable entry as practical. Canadian installations shall be properly grounded in accordance with the Canadian Electrical Code, Part 1.

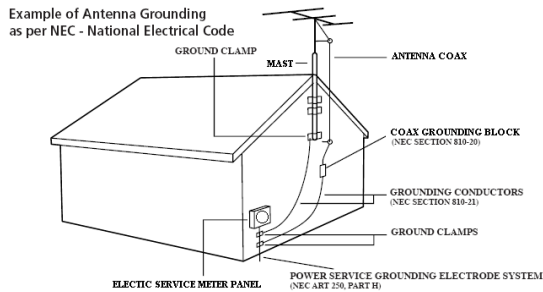

FCC

This equipment has been tested and found to comply with the limits for a Class A digital device, pursuant to part 15 of the FCC Rules. These limits are designed to provide reasonable protection against harmful interference when the equipment is operated in a commercial environment. This equipment generates, uses, and can radiate radio frequency energy and, if not installed and used in accordance with the instruction manual, may cause harmful interference to radio communications. Operation of this equipment in a residential area is likely to cause harmful interference in which case the user will be required to correct the interference at his own expense.

Maintenance and Servicing

The TV does not require periodic maintenance other than cleaning. Never remove the back cover of the TV; this can expose you to high voltage and other hazards. If the TV does not operate properly, unplug it and call an authorized service center or PDi.

Cleaning and Disinfection

Clean the exterior of this television by removing dust with a lint-free cloth. Spot test a new disinfectant by test cleaning a non-obvious small spot on the TV's back cabinet, keypad, and LCD panel. PDi recommends using a premoistened disinfectant cloth, like PD600-001 Super Sani-Cloth or similar, or spraying cleaner onto a dry cloth and then wiping the unit. Specific recommendations can be found at www.pdiarm.com. **CAUTION:** To avoid damage to the surface of the television, do not use abrasive or chemical cleaning agents.

Product Modification

Do not attempt to modify this product in any way without written authorization. Unauthorized modification could void the user's authority to operate this product.

Copyright, Trademarks

© 2021 PDi Communication Systems, Inc. All rights reserved. PDi®, medTV®, and medTAB® are registered trademarks of PDi Communication Systems, Inc. Manufactured under license from Dolby Laboratories. Dolby, Dolby Audio, and the double-D symbol are trademarks of Dolby Laboratories. The terms HDMI, HDMI High-Definition Multimedia Interface, and the HDMI Logo are trademarks or registered trademarks of HDMI Licensing Administrator, Inc. Product logos, brands and other trademarks displayed within PDi's products are the property of their respective trademark holders, who are not affiliated with, endorsing, or sponsoring PDi Communication Systems, Inc. or our products.

Underwriters Laboratories

This model Hospital Grade LCD HDTV is a specialized TV and should be installed to National Electrical Code specifications. This device is safety tested and listed by the Underwriters Laboratories as a product suitable for use in healthcare facilities in both the United States and Canada.



Disclaimer

The author and publisher have used their best efforts in preparing this manual. PDi Communication Systems, Inc. makes no representation or warranties with respect to the accuracy or completeness of the contents of this manual and specifically disclaims any implied warranties or merchantability or fitness for any purpose and shall in no event be liable for any loss of profit or any other damages. The information contained herein is believed accurate, but is not warranted, and is subject to change without notice or obligation.

IMPORTANT SAFETY INSTRUCTIONS

CAUTION: THIS INSTALLATION SHOULD BE MADE BY A QUALIFIED SERVICE PERSON AND SHOULD CONFORM TO ALL LOCAL CODES. READ AND FOLLOW THE SAFETY INSTRUCTIONS BEFORE ATTEMPTING THIS INSTALLATION.

1. Read Instructions – All the safety and operating instructions should be read before the product is operated.
2. Keep these Instructions – The safety and operating instructions should be retained for future reference.
3. Heed all Warnings – All warnings on the product and in the operating instructions should be adhered to.
4. Follow all Instructions – All warnings on the product and in the operating instructions should be followed.
5. Water and Moisture – Do not expose this product to rain or moisture. Do not use this product near water – for example, near a bath tub, wash bowl, kitchen sink, or laundry tub; in a wet basement; near a swimming pool; and the like.
6. Cleaning – Please see specific recommendations under “Cleaning and Disinfection” on previous page.
7. Ventilation – Slots and openings in the cabinet are provided for ventilation to ensure reliable operation of the product and to protect it from overheating. These openings must not be blocked or covered. The openings should never be blocked by placing the product on a bed, sofa, rug, or other similar surface. This product should not be placed in a built-in installation such as a bookcase or rack unless proper ventilation is provided, or the manufacturer’s instructions have been adhered to.
8. Heat – The product should be situated away from heat sources such as radiators, heat registers, stoves, or other products (including amplifiers) that produce heat.
9. Power-Cord Protection – Protect the power cord from being walked on or pinched, particularly at plugs, convenience receptacles, and the point where they exit from the product.
10. Attachments – Only use attachments/accessories specified by the manufacturer.
11. Use only with cart, stand, tripod, bracket, or table specified by the manufacturer, or sold with the apparatus. When a cart is used, use caution when moving the cart/apparatus combination to avoid injury from tip-over.
12. Lightning – For added protection for this product during a lightning storm, or when it is left unattended and unused for long periods of time, unplug it from the wall outlet and disconnect the antenna or cable system. This will prevent damage to the product due to lightning and power-line surges.
13. Servicing – Refer all servicing to qualified service personnel. Servicing is required when the apparatus has been damaged in any way, such as power cord or plug is damaged, liquid has been spilled or objects have fallen into the apparatus, the apparatus has been exposed to rain or moisture, does not operate normally, or has been dropped.
14. Oxygen Environment – Do not use in an oxygen tent or oxygen chamber. Such use may cause a fire hazard.
15. To prevent injury, this apparatus must be securely attached to the wall in accordance with the installation instructions. TV’s can pose a striking hazard when mounted at an elevated level.
16. Power Sources – This product should be operated only from the type of power source indicated on the marking label. If you are not sure of the type of power supply to your home, consult your product dealer or local power company. For products intended to operate from battery power, or other sources, refer to the operating instructions.

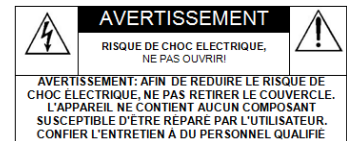
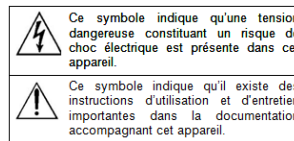

**CONSIGNES DE SÉCURITÉ IMPORTANTES
CETTE INSTALLATION DOIT ÊTRE EFFECTUÉE PAR UN
TECHNICIEN QUALIFIÉ ET DOIT ÊTRE CONFORME À TOUS LES
CODES LOCAUX. LIRE ET SUIVRE LES CONSIGNES DE SÉCURITÉ
AVANT DE PROCÉDER À L'INSTALLATION.**

1. Lire ces instructions.
2. Conserver ces instructions.
3. Respecter tous les avertissements.
4. Suivre toutes les instructions.
5. Ne pas utiliser cet appareil près de l'eau - par exemple près d'une baignoire, d'un lavabo, dans un sous-sol humide, ou près d'une piscine ou similaire.
6. Veuillez voir les recommandations sous “Nettoyage et Désinfection” à la Page précédente.
7. Ne pas obstruer les ouvertures de ventilation. Installer conformément aux instructions du fabricant. Les ouvertures ne doivent jamais être obstruées en plaçant le produit sur un lit, un canapé, un tapis ou toute autre surface similaire.
8. NE PAS installer près de sources de chaleur telles que radiateurs, registres de chaleur, poêles ou tout autre appareil (y compris les amplificateurs) qui produit de la chaleur.
9. NE PAS neutraliser le dispositif de sécurité de la fiche polarisée ou de terre. Ce produit est équipé d'une prise de terre à trois fils, une fiche ayant une troisième broche (mise à la terre). Cette fiche ne peut s'insérer que dans une prise de courant avec mise à la terre. Il s'agit d'une caractéristique de sécurité. Si vous êtes incapable d'insérer la fiche dans la prise, contacter votre électricien pour remplacer votre prise obsolète.
10. Protéger le cordon d'alimentation pour qu'il ne soit pas piétiné ni pincé, en particulier au niveau des fiches, des prises de courant et au point de sortie de l'appareil.
11. Accessoires - Utiliser uniquement les attaches/accessoires recommandés par le fabricant.
12. Utiliser uniquement avec un chariot, stand, trépied, support ou table recommandé par le fabricant ou vendu avec l'appareil. Lorsqu'un chariot est utilisé, faire attention lors du déplacement de l'ensemble chariot/appareil afin d'éviter des blessures en cas de basculement.
13. Débrancher cet appareil en cas d'orages ou lorsqu'il reste inutilisé pendant de longues périodes.
14. Confier toute réparation à un personnel de service qualifié. Des réparations sont nécessaires si l'appareil est endommagé d'une façon quelconque, par exemple : cordon ou prise d'alimentation endommagé, liquide renversé ou des objets sont tombés dans l'appareil, l'appareil a été exposé à la pluie ou à l'humidité, ne fonctionne pas normalement ou s'il est tombé.
15. Sources d'alimentation - Ce produit doit être utilisé uniquement à partir du type de source d'alimentation indiqué sur l'étiquette. Si vous n'êtes pas sûr sur le type d'alimentation de votre domicile, consultez le détaillant de votre produit ou la compagnie d'électricité locale. Pour les produits proposés de fonctionner par piles, ou autres sources d'alimentation, reportez-vous aux consignes d'utilisation.
16. Environnement d'oxygène - Ne pas utiliser sous une tente à oxygène ou chambre à oxygène. Une telle utilisation peut causer un risque d'incendie.

Technical Specifications*

CORE FEATURES		
OS		Android 5.0 (Lollipop)
CPU		Arm A9 Quad Core 1.0GHz
GPU		2D & 3D accelerator
Ethernet		100/1000 Mbps
RAM		1GB
Storage		8GB total. 3GB available for patient apps including up to 1GB for media files
USB Web Camera Compatible		YES
WIFI (OPTIONAL)		
WiFi Compatibility		802.11b/g/n/ac
WiFi Radio		Intel Dual Band Wireless-AC 3160
POWER		
Power		Consumption Max 13W
Voltage		12V DC

*Technical specifications could change without prior notice

Connections

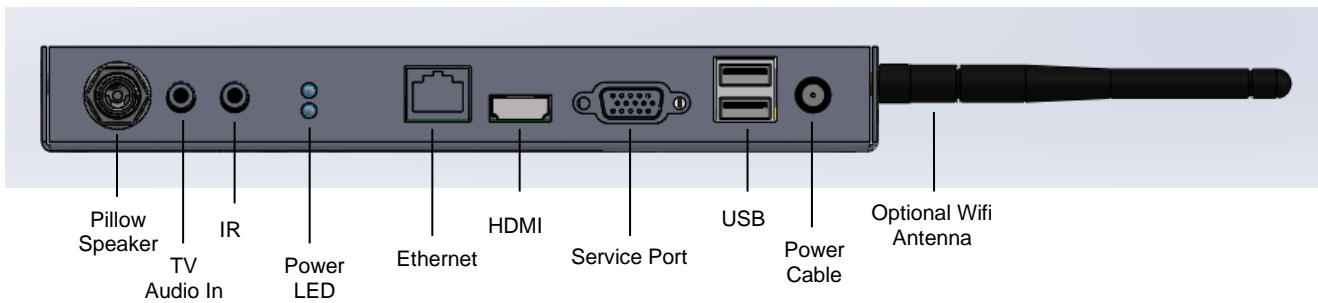

Installation

PDi offers a wide range of wall, floor and ceiling mounting options. Installation of the Universal Android Module is shown with compatible PDi brackets. Use of any other bracket may require modification of installation. The Universal Android Module contains a 100mm and 200mm VESA pattern. Contact PDi for compatible PDi bracket information.

Tool List:

1. Safety glasses/goggles
2. P1 or P2 Phillips screwdriver

Safety Steps:

1. Always wear safety glasses/goggles to prevent injury from debris.
2. Follow the installation/removal instructions for your existing products.

Parts List

PART NUMBER	QTY	DESCRIPTION
PD251-047	1	UNIVERSAL ANDROID MODULE
PD106-888	1	HDMI MALE TO MALE 36" CABLE
PD106-886	1	IR XMIT/RCV CABLE
PD196-370	1	QUICK START GUIDE, UNIVERSAL ANDROID MODULE
PDIPPHMSM4X710	2	M4 PHILLIPS SCREW
PDIPPHMSM6X110	2	M6 PHILLIPS SCREW

Mounting

The Universal Android Module is designed to mount to the rear of most televisions with standard 100mm or 200mm VESA mount points. These instructions assume the PDi PD168-033 mounting kit or PD168-103 mounting kit (Purchased Separately) are being used.

Step 1 (200mm Mounting Holes):

Loosen (2) M6 screws on the PD168-033 kit plate and insert Universal Android Module between plate and TV. Tighten (2) M6 screws.

Step 1 (100mm Mounting Holes):

Loosen (2) M4 screws on the PD168-103 kit plate and place Universal Android Module on top of mounting plate. Tighten (2) M4 screws.

Step 2:

Remount the television per manufacturer's installation instructions for your product.

Mounting using 200mm holes

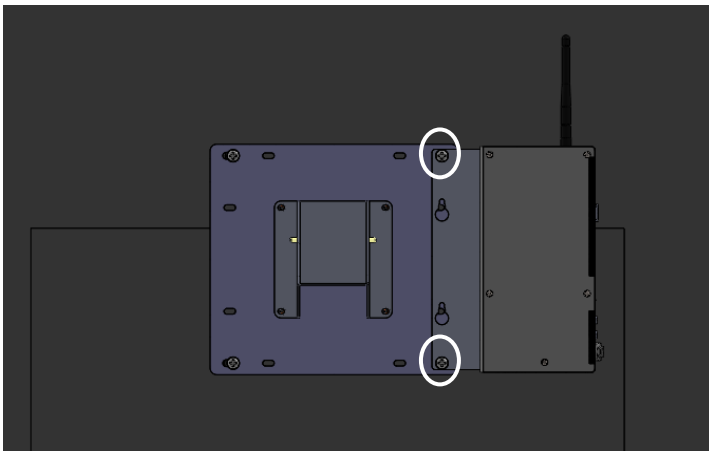

Mounting using 100mm holes

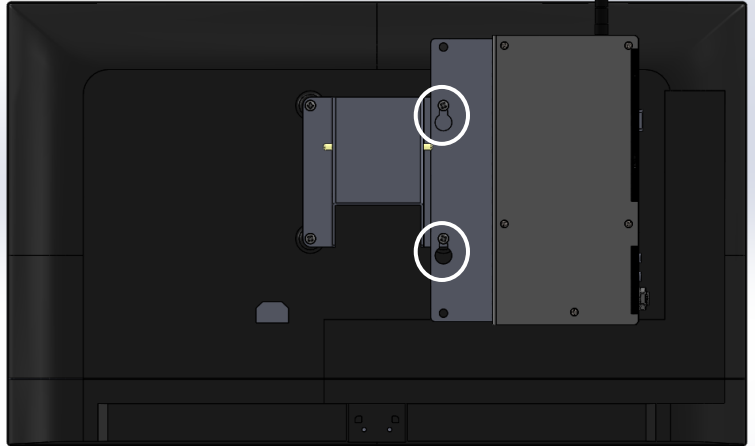

Ground Connection

1. Obtain 10AWG (or lower) stranded copper wire with 90°C green/yellow-stripe insulation, or as required by local electrical code.
2. Terminate the wire at one end with Panduit P10-8RHT6 or equivalent listed terminal (not included) for a #8 screw.
3. Terminate the other end of the wire as appropriate for your installation.
4. Connect one end of the grounding cable to a permanent earth ground, such as the AC outlet wall plate.
5. Place the ring terminal attached to the grounding cable over a #8-32 screw (not included).
6. Secure the grounding screw to the protective earthing location on the module.

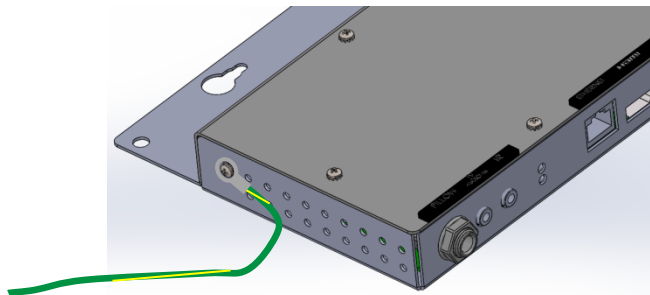

IR Cable Connection

1. Attach the supplied Infrared (IR) transmitter/receiver cable to the Universal Android Module's "IR" connector.
2. The small end of the cable is the IR transmitter. It must be affixed to the TV on top of the TV's IR window so that the TV can see the signals sent from this transmitter.
3. It is recommended to use black electrical tape to cover the IR transmitter so no other signals will pass into the TV.
4. The device in the middle of the cable is the IR receiver. Mount it on the side of the TV or a nearby surface so that it can see the IR beam from the TV's remote control. If the TV's remote will not be used in this application, then skip this step. Note the Universal Module is not compatible with all TV's remote codes. Please contact PDI Communication Systems for compatibility information.

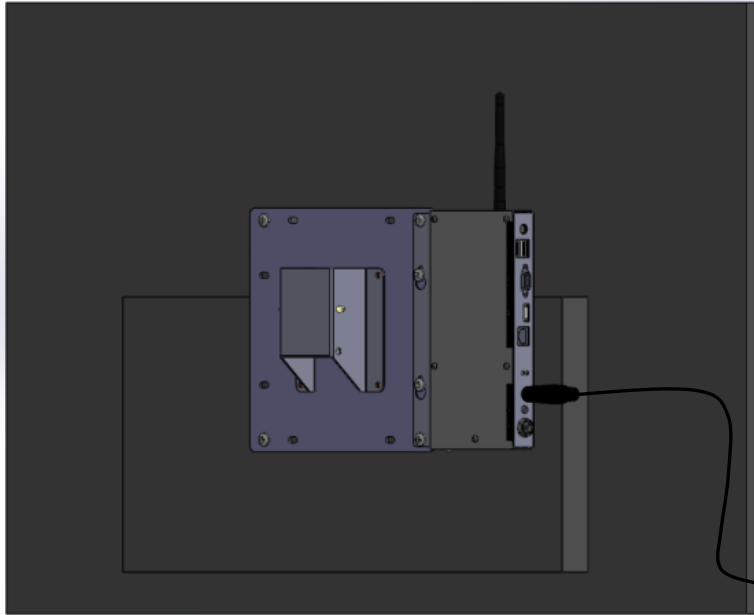

Pillow Speaker Connection

The PDi Universal Android Module is compatible with most pillow speakers available today including Philips, RCA and Zenith 5,6, and 7-bit codesets. The pillow speaker may connect directly to the Android Module, or it may route through a nurse call system. If routing through a nurse call system, a wall-to-module jumper cable will be used. In either case, the *data*, *speaker*, and *common* signals must terminate into a ¼" phone plug. Verify the proper termination then attach the phone plug to the module as shown.

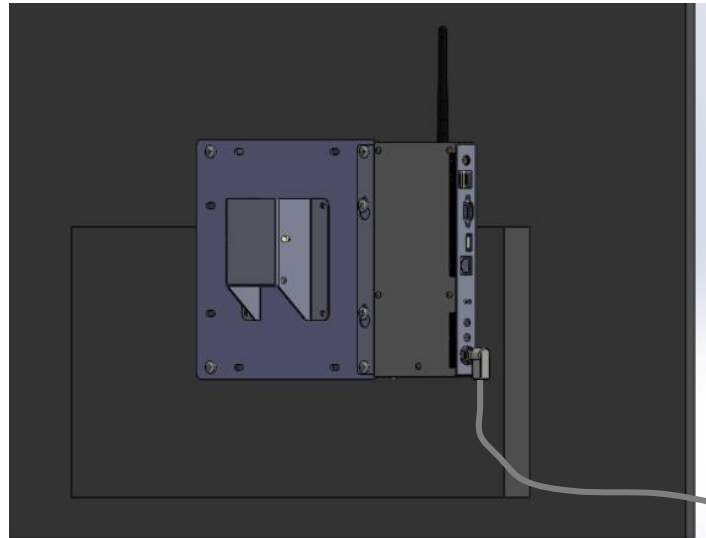

If needed, the following jumper cables may be ordered from PDi Communication Systems.

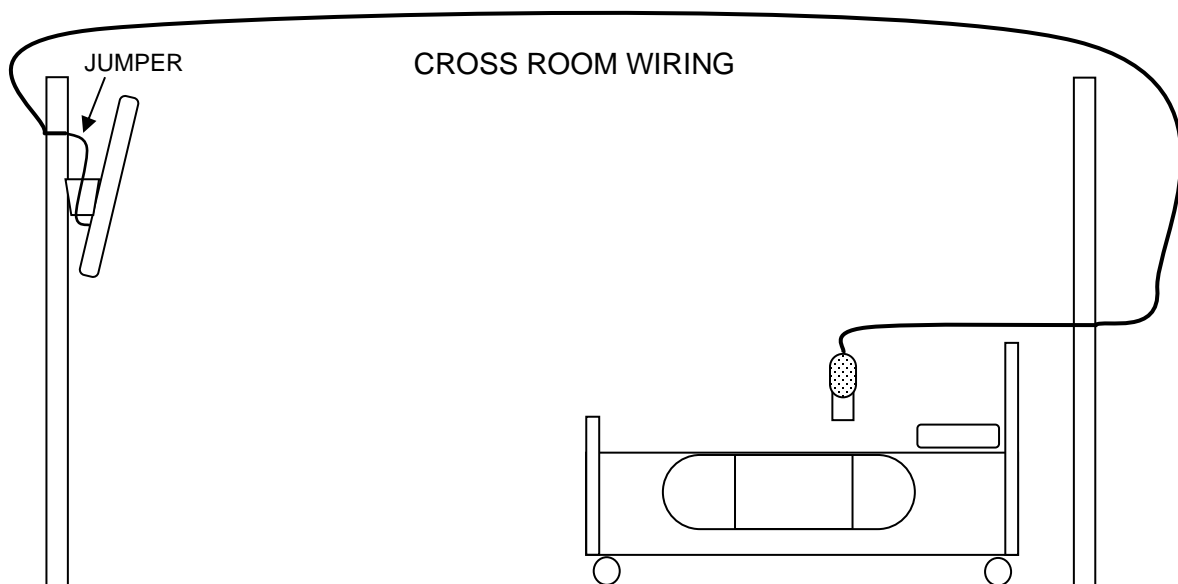
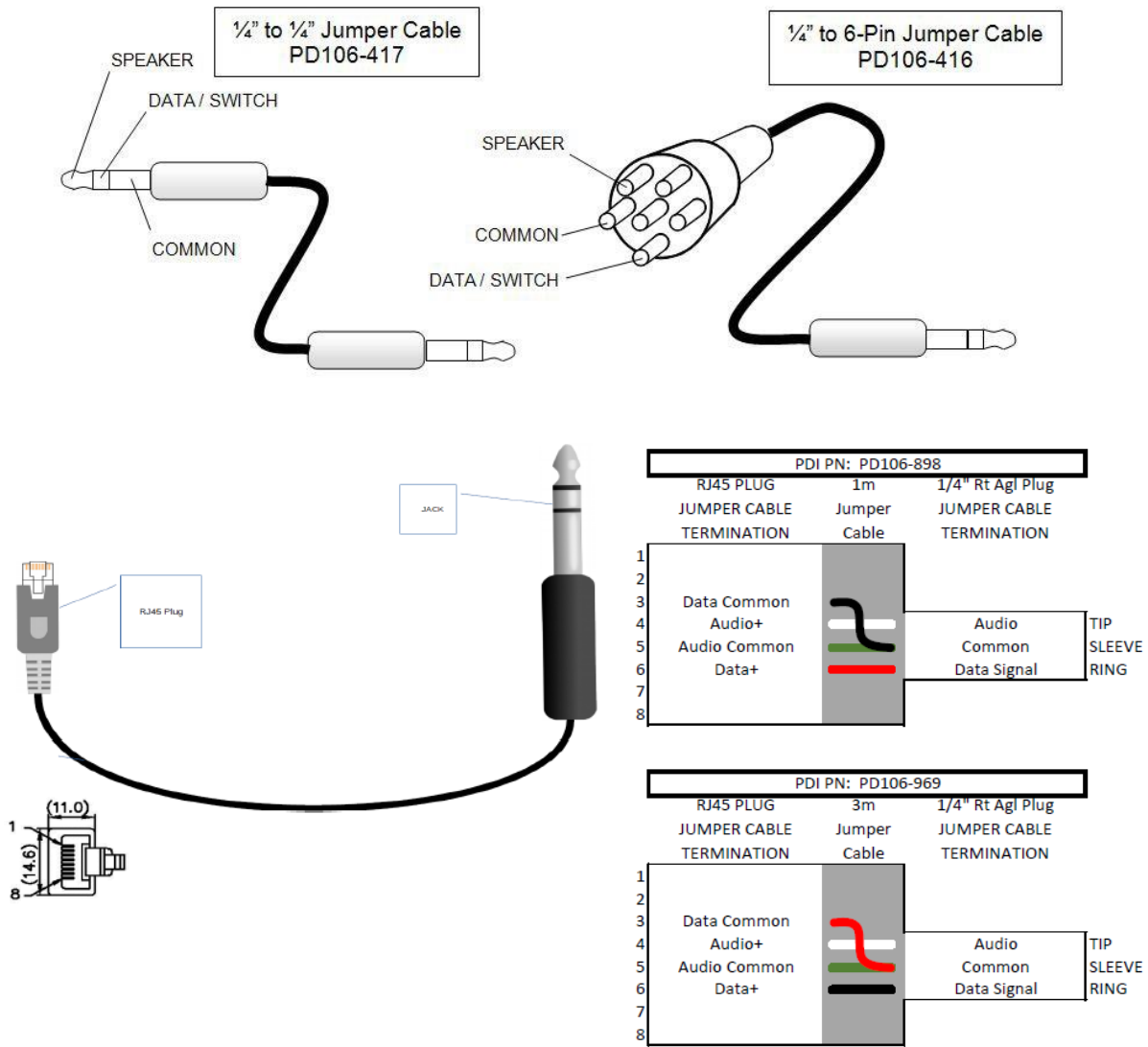

TV Audio Connection

The TV audio connection may or may not be required depending on your configuration. Pillow speaker audio can only come from one source, either direct from Android or from the TV audio output. If the TV speakers will not be used, Android audio is routed directly to the pillow speaker by disabling the Android setting “Internal Speakers”. The remainder of this section can be skipped.

The TV audio connection is only required in the following configurations to route sound from the TV to the pillow speaker.

- If the TV’s internal speakers are desired to play Android audio and/or
- The TV will be used to show audio/video from TV tuner or another HDMI source.

In the above situations, it is necessary to connect TV audio to the PDi Universal Android Module to route sound to the pillow speaker. Connect an appropriate audio patch cable (purchased separately) between the PDi Universal Android Module’s “TV AUDIO IN” connector and the TV’s audio output. Then enable the Android setting “Internal Speakers”.

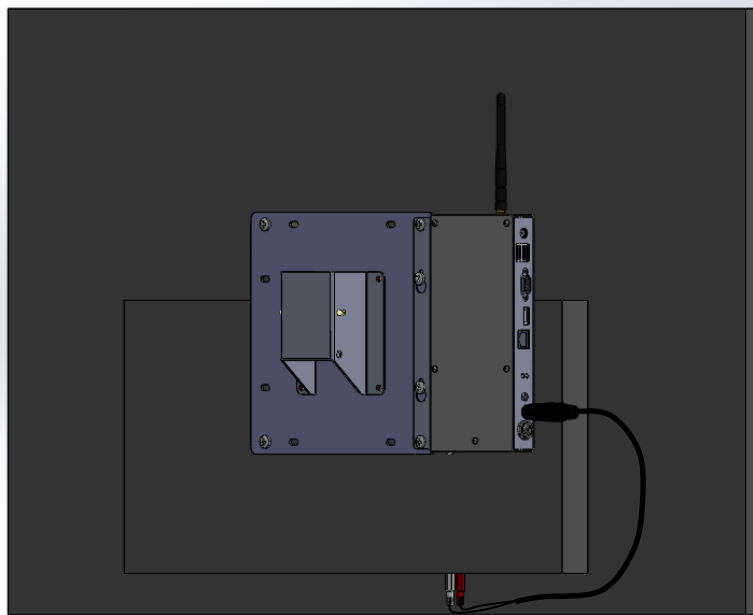

Power Adapter and HDMI Connections

Attach the supplied HDMI cable to the Universal Android Module. Attach the other end to any free HDMI port on the TV.

Finally attach the PDi PD239-237 power adapter to the PDi Universal Android Module, then to AC power.

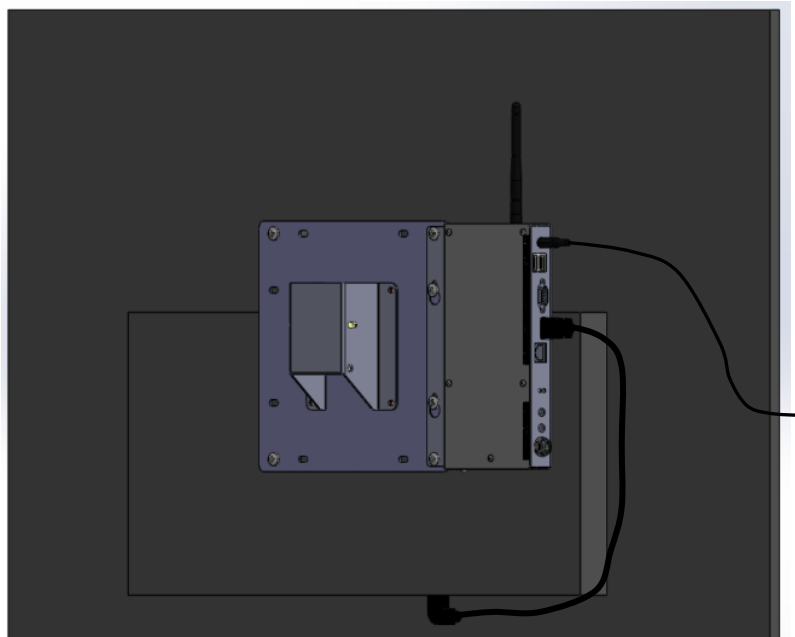

Screen Format Configuration

Set the TV to display the PDi Universal Android Module by choosing the corresponding HDMI input. The default screen format may be zoomed so that the edges are cropped. Repeatedly press the ARC or ASPECT button on the remote supplied with the TV until the on-screen display shows “Full Screen” or “Just Scan”.

Wireless Keyboard

You may have the PDi PD161-004 PDi wireless keyboard (purchased separately) or other compatible keyboard for use with this module. If you are using the PDi wireless keyboard, it will function as any 83 key QWERTY keyboard with several “Hot” keys.

Hot Keys	Function
Fn/Pair	Pair Keyboard with Module
Esc	Back one screen
Fn/Home	Home screen

Android Settings

From the android home screen select “ALL APPS” icon , then select “Settings”. You will enter the screen where you can adjust network, sound, and account settings.

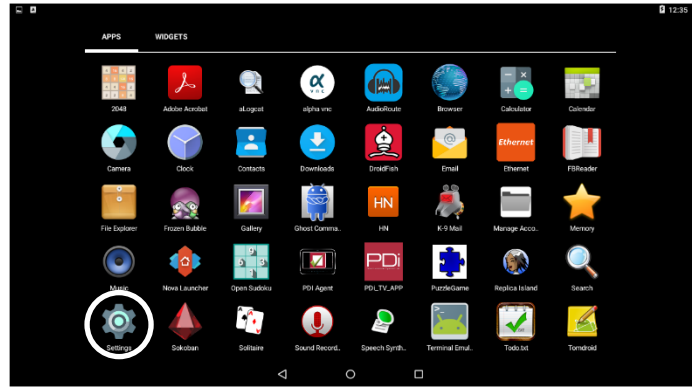

TV Speaker Enable

Android audio can only be directed to one output, pillow speaker or TV (via HDMI). This is controlled by an Android setting called “Internal Speakers”. Here “internal speakers” refers to the television’s speakers. If the TV speakers will not be used, Android audio must be routed directly to the pillow speaker by setting the “Internal Speakers” to disabled. Disabling internal speakers routes Android audio to the pillow speaker without the use of the external audio cable.

Enabling internal speakers is required in the following configurations to route Android sound to the TV.

- If the TV’s internal speakers are desired to play Android audio and/or
- The TV will be used to show audio/video from TV tuner or another HDMI source.

In the above situations, it is necessary to connect TV audio to the PDi Universal Android Module using an audio patch cable to route sound to the pillow speaker. See section “TV Audio Connection” above.

1. Open Settings and select “Sound & notification”.

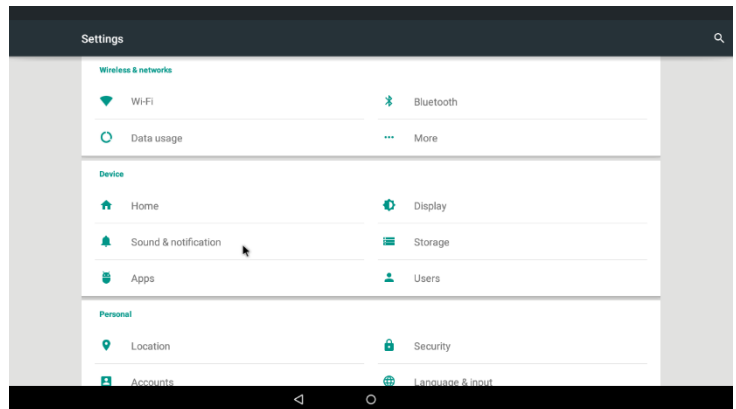

2. Select “Other sounds”.

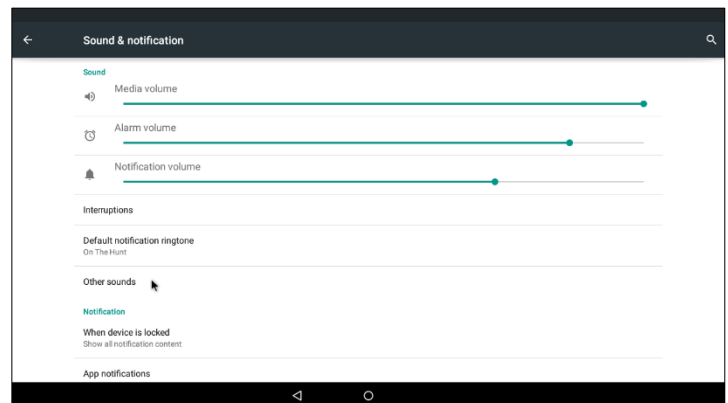

3. Enable or disable "Internal speakers" as required.

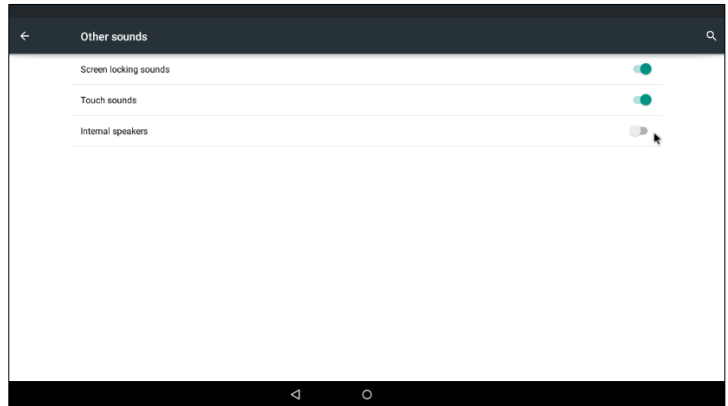

Connect To Wi-Fi Networks (Optional)

If the PDi Universal Android Module has the Wi-Fi option, follow the instructions to connect to a wi-fi network.

4. Open Settings and select “Wi-Fi”.

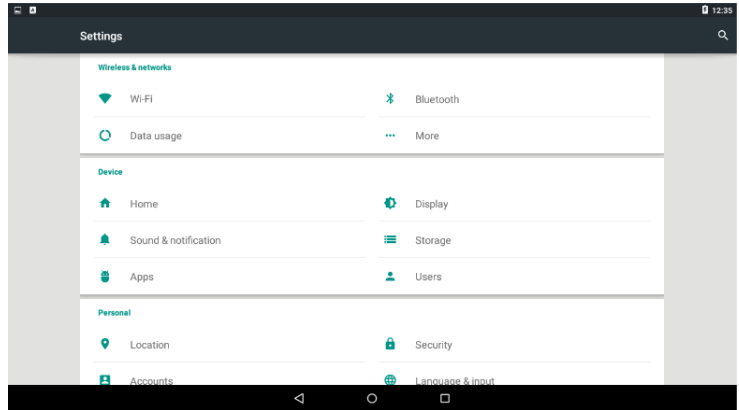

5. Slide the Wi-Fi switch to the *On* position.
(If not already set to “on”)

6. The module scans for available Wi-Fi networks and displays the names of those it finds. Secured networks are indicated with a  *locked* icon.

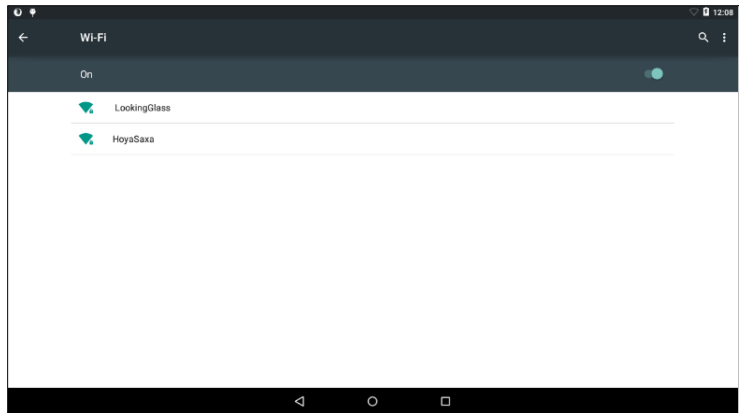

7. If the module finds a network that it connected to previously, it reconnects.

8. Select a network name to see more details or connect to it. Type a security code if necessary.

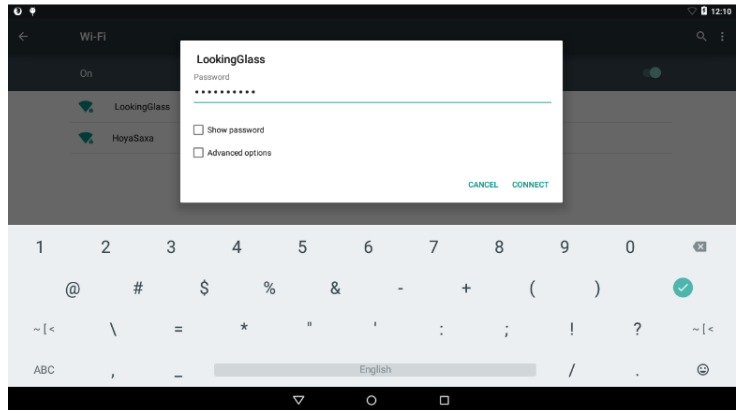

Troubleshooting

TV or Android Module Unresponsive

If the TV becomes unresponsive, remove power from the PDi Universal Android Module and reconnect power.

Pillow Speaker not Controlling Android

Verify the cross room wiring, between pillow speaker wall jack and TV wall jack, matches the chosen wall-to-module jumper cable.

Verify the pillow speaker codeset is compatible with the PDi Universal Android Module, not the TV. Nurse call systems like the Rauland R5 have configurable keycodes.

Pillow Speaker not Controlling TV

Verify the IR cable (shipped with the PDi Universal Android Module) is connected properly to the module. Verify the IR transmitter is mounted properly to control the TV. Verify the IR receiver is mounted properly to receive signals from the TV remote control (if used).

Pillow Speaker has no Audio

Verify the Android "Internal speakers" setting is correct.

If your configuration requires a TV audio cable, verify the cable is properly installed. See "TV Audio Connection" section. Then verify the TV is configured to send audio to the audio output connector.

Additional Information

Additional information is available in the user manual. You can access this information online at <http://pdidisplay.com>. For instructional installation video go to <http://youtube.com/pdiuniversity>.

Limited Warranty

PDi Communication Systems Inc., ("PDi") warrants, to the original purchaser only, that the product will be free from defects in materials and workmanship, under normal use, for 2 years from the date of original purchase. This warranty does not cover any other equipment that may have been included with PDi's shipment of this product.

After receipt of written notice of a defect or malfunction occurring during the warranty period, PDi will repair or replace goods returned to its Springboro, Ohio location, at its discretion, the whole or any component part of any product manufactured by PDi and found by PDi to be defective. If the decision is made to replace the product, PDi will exchange the model for the same model or a model similar in form and function.

As a condition to obtaining warranty service, written notification of the defective product must be received by PDi within ten (10) days of noticing the defect. Repair of said product requires it to be shipped to the PDi factory in Springboro, Ohio. All shipments shall be F.O.B. Springboro, Ohio, and all shipping and freight charges to PDi's factory shall be paid by the customer.

For information regarding authorized servicing and all other information pertaining to this warranty, please contact PDi COMMUNICATION SYSTEMS at 40 Greenwood Lane, Springboro, Ohio 45066 or phone 800-628-9870 and ask for Service.

This warranty gives specific legal rights and you may also have other rights which vary from state to state.

Exclusions from Warranty

- Products damaged by any catastrophe, accident, or from neglect, misuse, fault, improper assembly, improper maintenance, inadequate return packaging, or negligence by the customer or any third party. They will be treated as out of warranty for external cause to the Products, such as, but not limited to, failure of or faulty electric power, air conditioning, operator error, failure or malfunction of any data communications system. Such conditions will be determined by PDi at its sole unfettered discretion.
- Service and repair of accessories, apparatus, attachments or any other devices which are not PDi products or options.
- Defacing of product, revision control and PDi labeling (label alterations, serial number missing, serial number no longer discernible and serial number invalid). All serial numbers are recorded and tracked for warranty purposes.
- Unauthorized changes, modifications or alterations in or to the Products not installed by PDi.
- Damage to or loss of any programs, data, or removable storage media.
- Damage incurred during installation, relocation or removal of the Products or any accessories, apparatus, attachments or other devices.
- Normal wear.
- The furnishing of accessories or supplies.
- Damage by shipping carrier.
- Incompatibility issues.
- Damages of any kind including, but not limited to, direct or indirect damages, lost profits, lost saving, or other special incidental, exemplary or consequential damages whether for breach of contract, tort or otherwise, or whether arising out of the use of or inability to use the product, even if PDi or any distributor, dealer, or authorized service provider has been advised of the possibility of such damages, or any claim by any other party
- Damage caused by any software or application not installed at the factory.

PDi's liability under this warranty is limited to repair or replacement of defective products and parts as provided above. PDi shall not be liable for incidental or consequential damages.*

The warranty contained herein is in lieu of all other expressed or implied warranties, including any implied warranty of merchantability or fitness for any particular purpose. PDi neither assumes nor authorizes any person to assume, on its behalf, any other obligation or liability.

*Some states do not allow the exclusion of limitation of incidental or consequential damages or a disclaimer of warranties implied by law, so the above limitation or exclusion may not apply.

The information and technical data in this manual is believed accurate, but is not warranted and is subject to change without notice or obligation. PDi reserves the right to change this policy without advance notice.