

ASSEMBLY OF LCD PAN ASSEMBLY KNUCKLE:

- 1) ASSEMBLE THE PAN OPTION KNUCKLE PER THE FIGURES BELOW.
- 2) TIGHTEN THE FASTENERS UNTIL A SMALL AMOUNT OF RESITANCE IS PRESENT.
- 3) ATTACH KNUCKLE BETWEEN DESIRED MOUNTS USING SUPPLIED PDIBHSCS2520 50 FASTENERS AND PDFIW25 FLAT WASHERS, PER MOUNTING DIRECTIONS SUPPLIED WITH THOSE MOUNTS.

** THIS ITEM HAS ALSO BEEN REFERRED TO AS THE PDI-MB1**

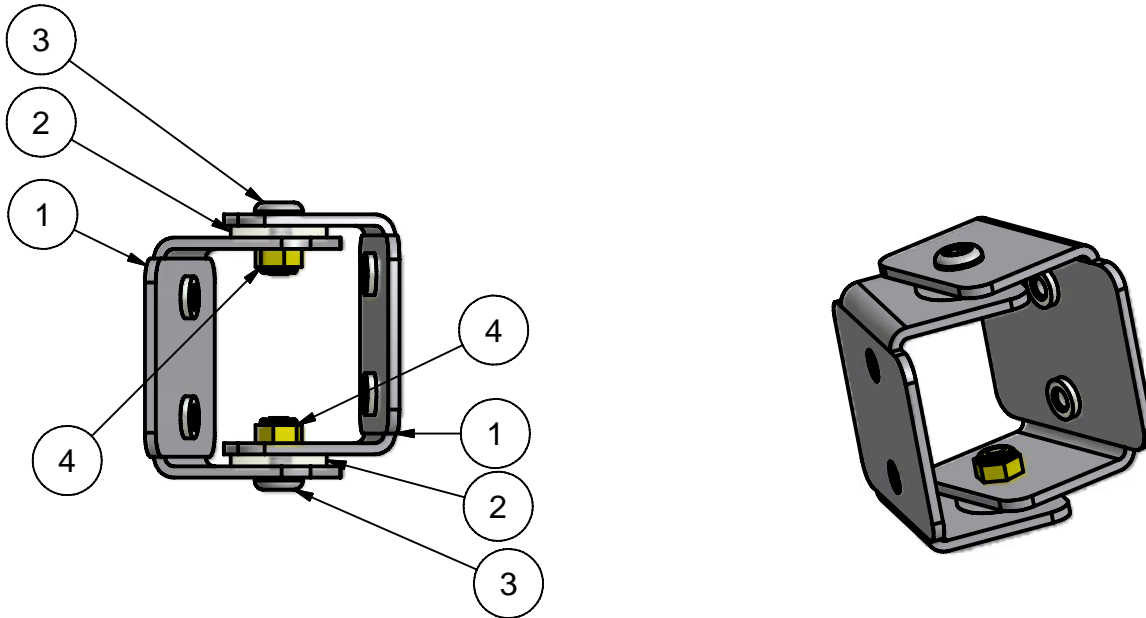

Parts List			
ITEM	QTY	PART NUMBER	DESCRIPTION
1	2	PD181-607	SHORT LCD CLEVIS
2	2	PDI1172	FRICTION WASHER
3	2	PDIBHSCS 2520 62	1/4-20X5/8 BHSCS
4	2	PDISLN 2520	1/4-20 STOVER LOCK NUT
	4	PDHBHSCS 2520 50	1/4-20X1/2 BHSCS
	4	PDFIW 25	1/4" FLAT WASHER