

Place the PDI-242C Rotational Stop Plate on the wall bracket, so the large hole in the rotational stop is around the top of the bushing and the straight edge to the rear. Next, place the arm into the wall bracket. Place a 10-32 x 1-1/4 screw thru the PDI-243, plastic stop. Rotate the arm to the left or right until the desired position is found. Place the screw/stop thru the closest hole in the PDI-242C and next to the arm base that will not allow the arm to rotate beyond the desired position. Now, place a 10-32 Nylock insert lock nut on the screw and tighten until the stop is secure. Repeat for the opposite side if needed.

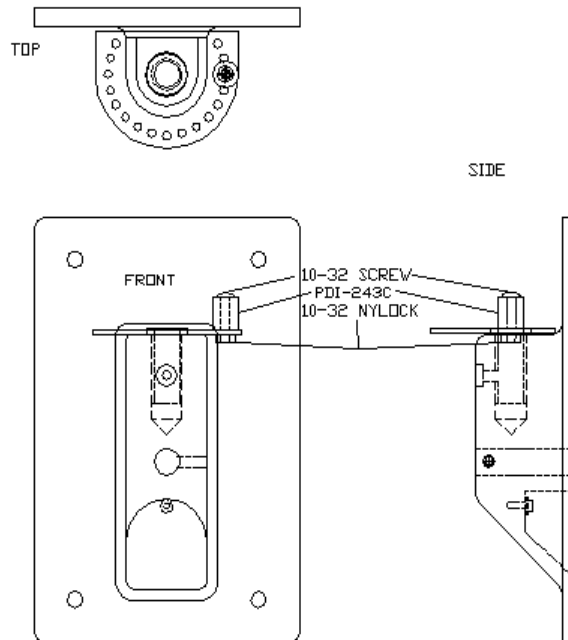

**EXAMPLE OF MOUNTING WITHOUT ARM INSTALLED**