

PDi Healthcare Televisions and Patient Entertainment Systems



THE PDI-P10DVB-T AND PDI-P15X SET THE NEW STANDARD FOR THE PERSONAL SWING ARM MOUNTED LCD TELEVISIONS.

THE PDI-P15X PROVIDES MULTIPLE CONFIGURATIONS INCLUDING STANDARD TV ONLY, TOUCHSCREEN APPLICATIONS, NETWORKING, HIGH-END COMPUTING, GAMES AND INTERNET ACCESS.

BOTH COMBINE ANTIMICROBIAL PLASTIC, MULTIPLE MOUNTING OPTIONS INCLUDING SWING ARM, CEILING, WALL, CHAIR OR FLOOR PROVIDING A SOLUTION FOR EVERY FACILITY'S NEEDS.

Thoughtful design for caring environments

The PDi brand brings a new standard of excellence and caring design to healthcare entertainment systems. Uniquely designed just for healthcare environments -- including hospitals, dialysis clinics and nursing homes -- the Digital 10" and 15" LCD Personal Television offers a sleek and state-of-the-art alternative to bulky, space-hungry, wall-mounted CRT TVs. The friendly, approachable design and ergonomic controls provide a more pleasant user experience. With its sharp, bright display, high-tech appearance, and thin profile, it is the perfect enhancement for individual patient applications. Plus, its long-lasting components, flexible user features, ease of maintenance and competitive pricing provide strong business advantages for facility managers today ... and far into the future.

Made in the USA -- All PDi products are designed by PDi Engineers and is produced in the USA in a state-of-the-art, ISO certified facility.

CE mark; complies with EN 60065, EN 55013 & EN 55020. Meets healthcare industry standards with AC power supply via a coax cable.

Designed exclusively for Healthcare applications -- not a converted consumer product or dual-purpose commercial unit.

A better, more personal view - state-of-the-art LCD Panel provides high resolution, high contrast images across a very wide viewing angle.

Speakers can be programmed for use with earphones or left on for patient and guest convenience.

Long lasting -- The LCD Panel is rated for 50,000 hours. That's 11 years of typical use. Plus, the screen quality won't degrade over time like CRTs.

ADA Compliant, hermetically sealed and medical grade membrane keypad features direct channel access with last channel recall and patient activated closed captioning.

Clone Programmable for efficient install

Lightweight televisions install easily with precabled PDi 400 or 500 Series Arms and with individual Power Supplies (PDI- 958).



PANEL		
	P10	P15X
Screen Size	25.4cm	38cm
Aspect Ratio	4:3	4:3
Native Resolution	640x480	1024x768
Brightness	350 cd/m ²	400 cd/m ²
Contrast Ratio	400:1	500:1
Viewing Angle	110°x 110°	160°x 140°
Color Depth	16.7 Mil	16.7 Mil
Lamp Life	50k Hours	50k Hours
Response Time	12 ms	8 ms
Unit Weight	7 lbs	13lbs

Shared features on P10 and P15X

VIDEO

DVB-T Tuner.....Air VHF /UHF, CATV
 QAM in the Clear.....CATV, IRC, HRC
 Channel.....1-69 V/UHF & 1-47 Cable

AUDIO

Speakers.....P10: 1 @ 1-watt RMS / P15X: 2 @ 5-watt RMS
 Analog.....Mono /Stereo/SAP
 Digital.....Dolby Digital
 Earphone.....Yes
 Radio Tuner.....Yes (P15x)

HEALTHCARE SPECIFIC AUDIO FEATURES

Audio Volume Limiter (AVL) PCM, AC3.....Yes
 Internal Speaker Disable.....Yes
 Min/Max Volume Limiter.....Yes
 Start/ Power-on Volume.....Yes

POWER

Source.....20-34 VAC 50 Hz Duplexed over Coax
 Consumption.....<30w

REGULATORY

CE EN 60065, 55013, 55020.....Yes

WARRANTY

2 Year Parts and Labor Standard

P15x INPUTS

RF.....Yes
 Composite.....Yes
 S-Video.....Yes
 Component.....Yes
 HDMI.....Yes
 VGA.....Yes
 PC Audio In.....Yes
 USB.....Yes
 Ci Card.....Yes
 SCART.....Yes

The P10 ONLY has RF input available

IR REMOTES

Program Remote.....Yes (PD108-420)

P10 & P15x SPECIFIC FEATURES

Antimicrobial plastic cabinet.....Yes
 Direct Access Keypad.....**Yes, sealed antimicrobial membrane**
 Touch Screen Configuration.....Yes (P15X only)
 (Auto Power On) On Time.....Yes
 Bed A / B.....Yes
 Programmable Source Selection.....Yes
 Channel Enable /Disable.....Yes
 Parental Guidance.....Yes Off, 4-18
 Clone Programmable.....Yes

SWING ARM MOUNTING OPTIONS

The P10 will fit on the **PDI-405C-7** and **PDI-508C-7** PDi swing arms.
 The P15x will fit on the **PDI-405C-12** and **PDI-508C-12** PDi swing arms.

POWER SUPPLY OPTIONS

Please use PDI-958 Power Supplies for P10 & PDI-750XL for P15x

Multiple floor, chair, counter and ceiling mounts are available. Please contact your PDi distributor or www.pdiarm.com for more information.

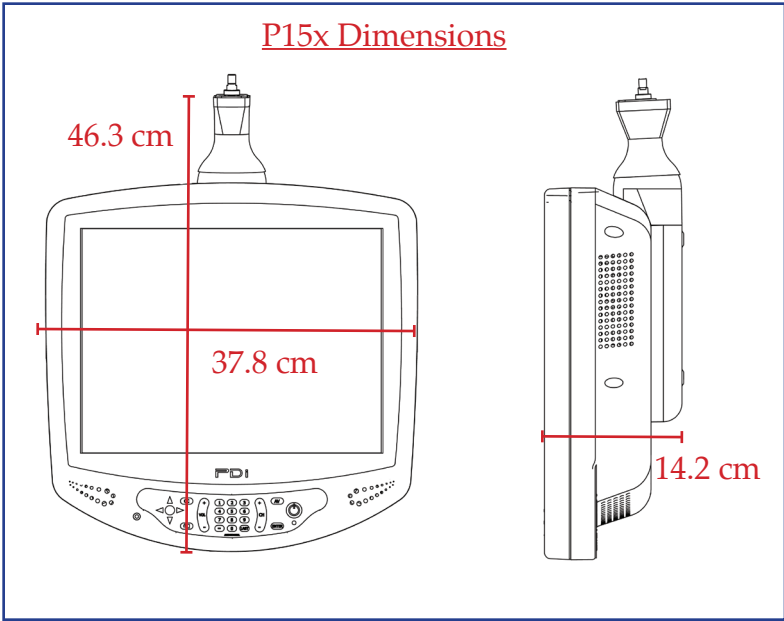
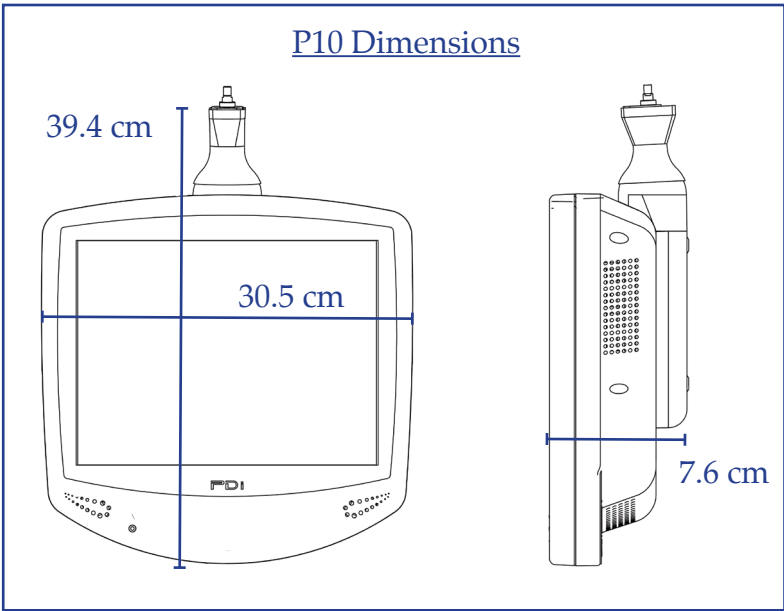



BETTER SOLUTIONS ARE IN REACH

Since 1980, PDI Communication Systems has grown to be the industry leader in advanced entertainment solutions and patient television systems for the North American healthcare market and continues to offer the broadest and best-supported line of healthcare specific LCD television solutions for this market.

It is a very exciting time at PDI. Capitalizing on our healthcare success and experience, we are proud to release a new line of new and innovative products tailored for the International market. We will be introducing our 10" and 15" low voltage support arm mounted, PAL/DVB-T LCD televisions, as well as other larger LCD TV's ranging in screen size from 15.6 (39.6), 19 (48.2), 22 (55.8), 26 (66), 31.5" (80cm), and an LED Backlit Ultra thin 18.5 (47) and 21.6" (54.9cm) PAL/DVB-T televisions. We can also offer high resolution monitors, 1MP, 2MP, 3MP, and even 5MP, Mono and Color, for all of your Radiological applications.

Our present plant is located in Springboro, Ohio, USA. This ISO certified 70,000 square foot facility houses all our operations. We currently have sales offices in Singapore and throughout Europe, with our EU Director of Sales headquartered in Italy.

We look forward to meeting with you and sharing our story.

EUROPEAN HEADQUARTERS:
ROBERTO DE LORENZIS, DIRECTOR
PDI COMMUNICATION SYSTEMS INC.,
VIA LA SPEZIA
73055 RACALE (LE), ITALY
WWW.PDIARM.COM OR 011-39-340 2167809

WORLD HEADQUARTERS:
PDI COMMUNICATION SYSTEMS INC.,
40 GREENWOOD LANE
SPRINGBORO, OH 45066 USA
WWW.PDIARM.COM OR 800-628-9870